

Sigen Gateway HomeMax TP

User Manual

Version: 02

Release date: 2024-04-30



Copyright Notice

Copyright© 2024 Sigenergy Technology Co., Ltd. All Rights Reserved.

Description in this document may contain predictive statements regarding financial and operating results, product portfolio, new technology, configurations and features of product. Several factors could cause difference between actual results and those expressed or implied in the predictive statements. Therefore, description in this document is provided for reference purpose only and constitutes neither an offer nor an acceptance. Sigenergy Technology Co., Ltd. may change the information at any time without notice.



SIGENERGY and other Sigenergy trademarks are owned by Sigenergy Technology Co., Ltd.

All trademarks and registered trademarks in this document belong to their owners.



Website



LinkedIn



YouTube

www.sigenergy.com

Contents

Revision History	4
Overview	5
Chapter 1 Safety Precautions.....	6
Chapter 2 Product Introduction.....	7
2.1 Product Model.....	8
2.2 Appearance Introduction.....	8
2.2.1 Appearance and Dimensions	8
2.2.2 Port Introduction.....	9
2.3 Label Description.....	11
2.4 Introduction to Typical Networking	12
Chapter 3 Site Selection Requirements	13
Chapter 4 Equipment Installation and Wiring	18
4.1 mySigen App Query	19
Chapter 5 System Maintenance	20
5.1 Routine Maintenance	20
5.2 Troubleshooting.....	21
5.3 Emergency Treatment.....	22
Chapter 6 Appendix.....	23
6.1 Technical Parameter	23

Revision History

Version	Date	Description
02	2024.04.30	Updated 2.4 Typical Networking Introduction Updated Chapter 3 Site Selection Requirements Updated 5.2 Troubleshooting
01	2024.02.01	First official release.

Overview

Introduction



The focus of this document is to provide an overview of the Sigen Gateway HomeMax TP, including product description, networking, system operation, maintenance, etc.

Readers

This document is suitable for product users and professionals.

Sign Definition

The following signs may be used in the document to indicate security precautions or key information. Before installation and operation, familiarize yourself with signs and their definitions.

Signs	Definition
 Danger	Danger. Failure to comply may result in death or serious personal injury.
 Warning	Danger. Failure to comply may result in serious personal injury or property damage.
 Caution	Caution. Failure to comply may result in property damage.
Tips	Important or key information, and supplementary operation tips.

Chapter 1 Safety Precautions

Basic Information

Before installing, operating, and maintaining the equipment, familiarize yourself with this document.

The "Danger ", "Warning", "Caution" items described in this manual are only supplementary to all precautions.

The Company shall not be liable for equipment damage or property loss caused by the following reasons:

- Failure to obtain approval from the national, regional power authority.
- The installation environment does not meet international, national, or regional standards.
- Failure to observe local laws, regulations and norms when operating and maintaining equipment.
- The installation area does not meet the requirements of the equipment.
- Failure to follow the instructions and precautions in this document.
- Failure to follow the warning labels on equipment or tools.
- Negligent, improper operation or intentional damage.
- Damage caused by your or a third party's replacement of our equipment.
- The equipment is damaged by your or the third-party company to use the accessories supplied with the package and purchase and use the accessories of the same specifications for installation.
- Equipment damage caused by improper operations such as disassembling, replacing, or modifying the software code without authorization.
- Equipment damage caused by force majeure (such as war, earthquake, fire, storm, lightning, flood, debris flow, etc.).
- Damage caused by the failure of the natural environment or external power parameters to meet the standard requirements of the equipment during actual operation (for example, the actual operating temperature of the equipment is too high or too low).

- The equipment was stolen.
- The equipment is damaged after the warranty period.

Safety Requirements

Danger

- Do not expose the device to high temperature or heat sources (such as sunlight, fire, or heaters) around the equipment for a long time.
- Do not clean or soak the equipment with water, alcohol, or oil to avoid power leakage.
- Do not knock or impact the equipment. In case of an accident, please stop using the equipment immediately and contact your installer. The equipment shall be inspected and evaluated by professional personnel before continuing to use.

Caution

- Do not use the equipment with faults. If the equipment appears abnormal (for example, appearance distortion), contact your installer.
- Carbon dioxide fire extinguishers and ABC dry powder fire extinguishers are recommended at home.

Do not use the equipment in the following situations:

- When connected to public infrastructure systems.
- When connected to emergency medical equipment.
- When connected to elevators and other control devices.
- Any other critical systems.

Chapter 2 Product Introduction

2.1 Product Model

Product code	Model No.	Name	Function specification
Gateway	Sigen Gateway HomeMax TP	Sigen Energy Gateway HomeMax Three Phase	It's applicable for PV storage applications to facilitate data acquisition and monitoring, off-grid backup power switching, diesel generator control, energy management; it must be used with SigenStor BAT and inverter.

2.2 Appearance Introduction

2.2.1 Appearance and Dimensions

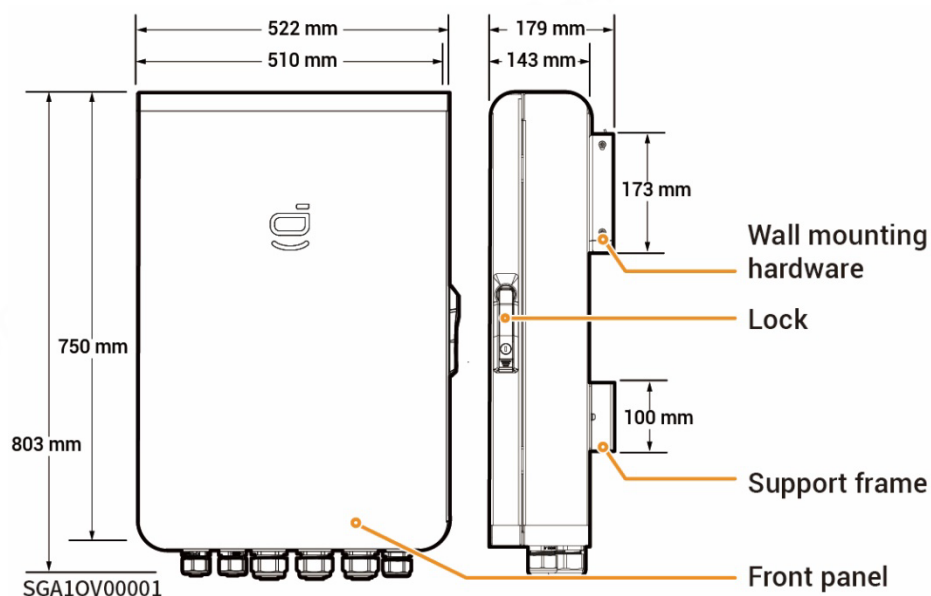

2.2.2 Port Introduction

Bottom View

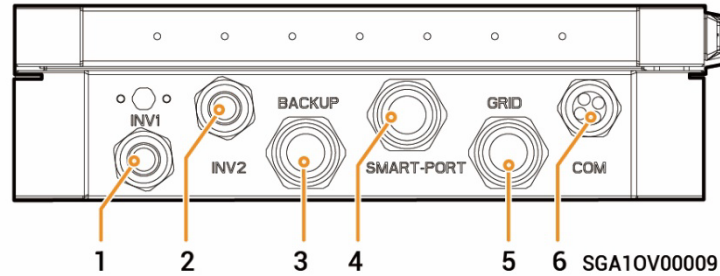



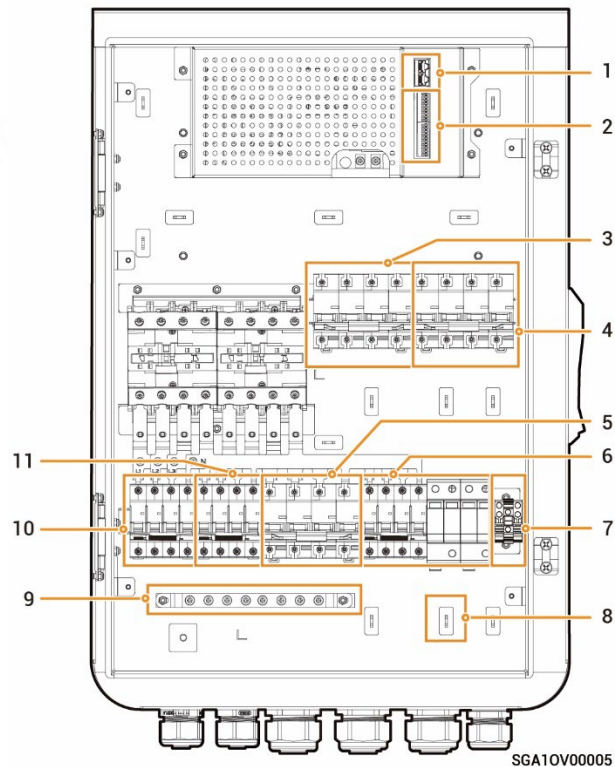

S/N	Name	Marking
1	Wire-in port of inverter 1	INV1
2	Wire-in port of inverter 2	INV2
3	Wire-in port of backup home loads	BACKUP
4	Wire-in port for smart loads /diesel generator	SMART-PORT
5	Wire-in port of power grid	GRID
6	Wire-in port of communication	COM

Interior View



S/N	Name
1	FE interfaces
2	DI, and DO interfaces
3	Miniature circuit breaker (Smart Loads/Diesel generator)
4	Miniature circuit breaker (Power grid)
5	Miniature circuit breaker (Backup home loads)
6	Miniature circuit breaker + Surge protection Device
7	GND
8	Cable clamp
9	Earthing bar
10	Miniature circuit breaker (Inverters 1)
11	Miniature circuit breaker (Inverters 2)

2.3 Label Description

Symbols	Definition
	Warning! Risk of High voltage. There is a risk of high voltage in the cover of the equipment. Please take precautions when operating the equipment.
	After the equipment is powered off, the discharge of internal components is delayed. Wait 5 minutes until the equipment is fully discharged according to the label time.
	Warning! Risk of burns. The surface of the heat dissipation area is hot when the equipment is running. Do not touch it to avoid burns.
	Please refer to the instructions to operate the equipment.
	Earthing mark

2.4 Typical Networking Introduction

The Gateway is designed for a on-grid and off-grid systems on for home rooftop PV power. The on-grid and off-grid systems consists of photovoltaic panel, Gateway, Battery pack, inverters, Backup home loadss, Loads, Power grid and other components.

Networking Diagram (Whole Home Backup)

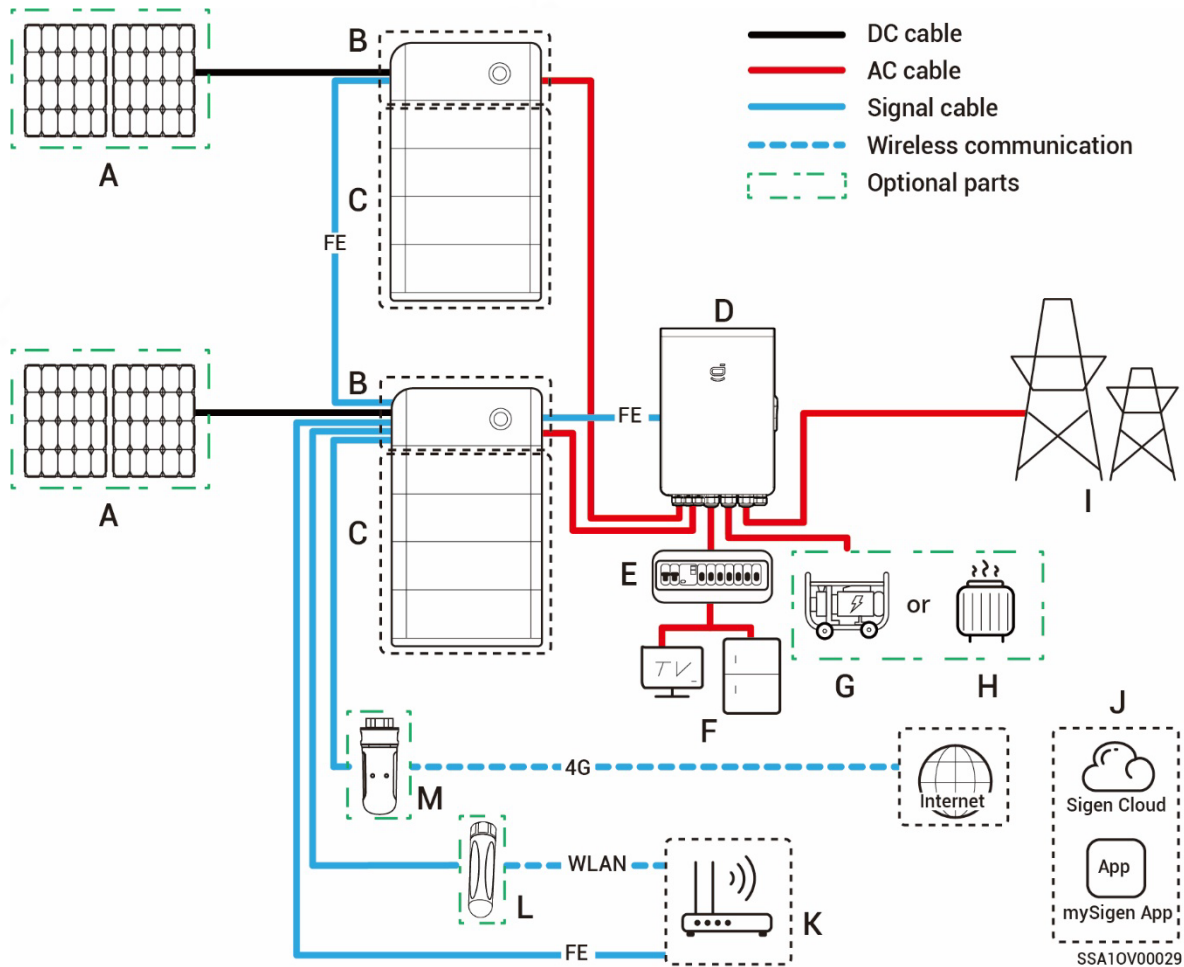

- | | |
|-----------------------------|---|
| A. PV panel | B. SigenStor EC/SigenStor AC /Sigen Hybrid |
| C. SigenStor BAT | D. Gateway |
| F. Backup home loads | E. Backup Backup home loads |
| G. Diesel generator | H. Smart loads |
| J. mySigen | I. Power grid |
| K. Router | L. Antenna |
| | M. CommMod |

Tips

- When B is SigenStor AC, A is not configured.
- As a backup energy source for long-term off-grid applications, the diesel generator can work in tandem with the Gateway to provide a smooth transition between PV, storage and diesel power generation.
- Smart loads are Low-priority loads such as heat pumps, pool heaters, and clothes dryers can be cut out when the energy storage capacity is insufficient.

- It is recommended to use FE and WLAN for communication with inverter. CommMod users must top up their own 4G data plan after a period of 2 years.

Networking Diagram (Partial Home Backup)

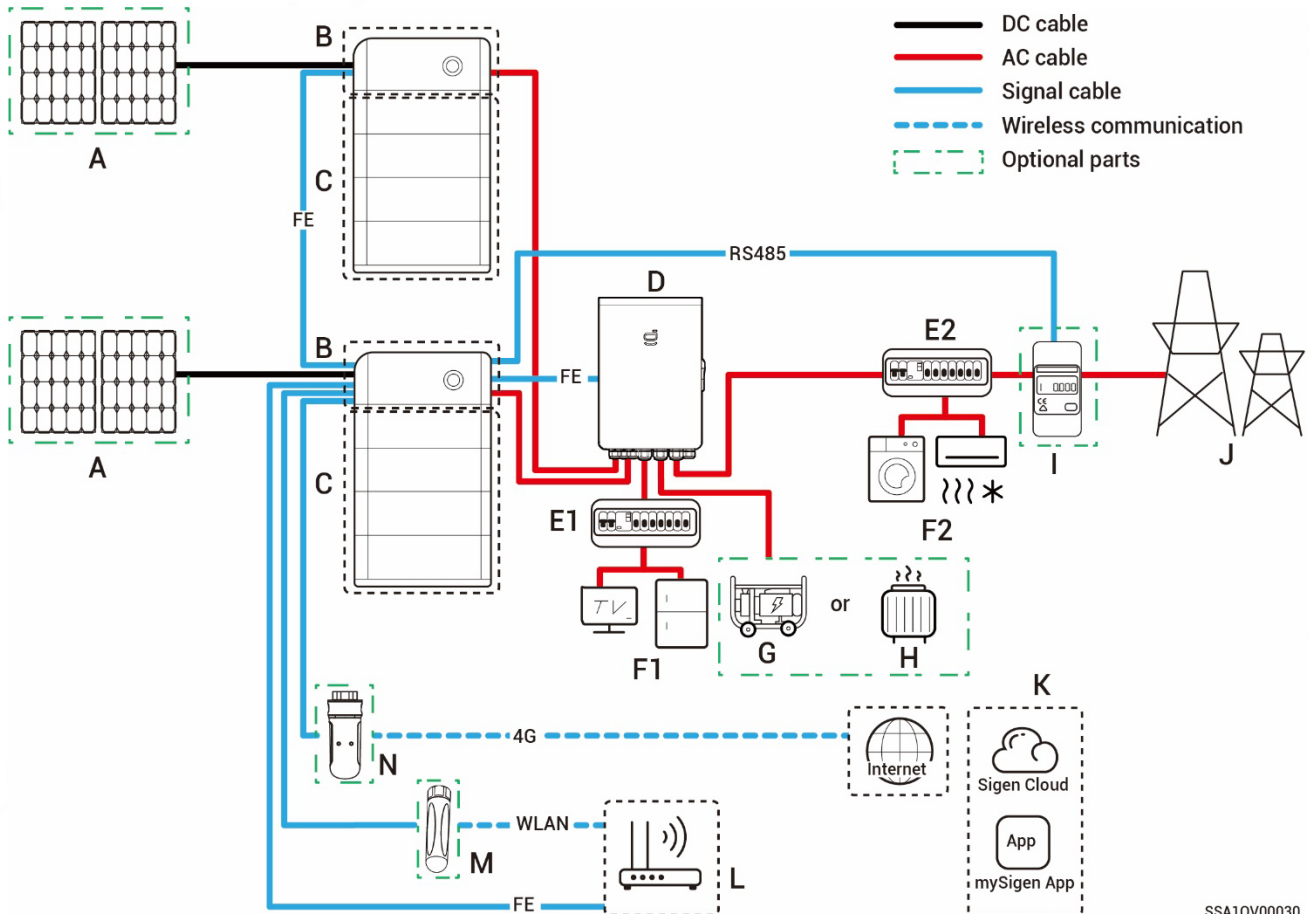

SSA10V00030

- | | | |
|---|---|-------------------------------------|
| A. PV panel | B. SigenStor EC/SigenStor AC /Sigen Hybrid | E1. Backup Backup home loads |
| C. SigenStor BAT | D. Gateway | F1. Backup home loads |
| E2. Non-Backup Backup home loads | F2. Non-Backup home loads | G. Diesel generator |
| F2. Non-Backup home loads | H. Smart loads | J. Power grid |
| I. Power sensor | K. mySigen | L. Router |
| M. CommMod | N. Antenna | |

Tips

- When B is SigenStor AC, A is not configured.
- Smart loads: Low-priority loads such as heat pumps, pool heaters, and clothes dryers can be cut out when the energy storage capacity is

insufficient.

- Power sensor has the function of data acquisition for grid connection points enables zero-power grid connection. For partial home backup, H does not need to be configured. For partial backup power and zero-power grid connection control networking, Power sensor is configured.
- As a backup energy source for long-term off-grid applications, the diesel generator can work in tandem with the Gateway to provide a smooth transition between PV, storage and diesel power generation.
- It is recommended to use FE and WLAN for communication with inverter. CommMod users must top up their own 4G data plan after a period of 2 years.

Chapter 3 Site Selection Requirements

Tips

The warranty applies when the equipment has been installed properly for its intended use and in accordance with the operating instructions.

Installation Environment Requirements

- Do not install the equipment in smoky, flammable, or explosive environments.
- Avoid exposing the equipment to direct sunlight, rain, standing water, snow, or dust. Install the equipment in a sheltered place. Take preventive measures in operating areas prone to natural disasters such as floods, mudslides, earthquakes, and typhoons.
- Do not install the equipment in an environment with strong electromagnetic interference.
- Ensure that the temperature and humidity of the installation environment comply with the equipment's requirements.
- The equipment should be installed in an area that is at least 500 m away from corrosion sources that may result in salt damage or acid damage (corrosion sources include but are not limited to seaside, thermal power plants, chemical plants, smelters, coal plants, rubber plants, and electroplating plants).

Installation Position Requirements

- Do not tilt or overturn the equipment to ensure that it is installed horizontally.
- Do not install the equipment in places easily touched by children.
- Do not install the equipment in places with fire or damp.
- Please keep away from the daily work and living places.
- Do not install the equipment in a sealed, poorly ventilated location without fire protection measures and difficult access for firefighters.

- Do not install the equipment in mobile scenarios such as RVS, cruise ships, and trains.
- You are advised to install the equipment in a location where you can easily access, install, operate, maintain it, and view the indicator status.
- When installing the equipment in the garage, do not install the equipment in the position where the vehicle passes through to avoid collision.

Mounting Surface Requirements

- Do not install the equipment on a flammable installation base.
- The installation base should meet the load-bearing requirement. Solid brick-concrete structures, concrete walls are recommended.
- The surface of the installation base must be smooth and the installation area must meet the installation space requirements.
- No water or electricity is routed inside the installation base to prevent drilling hazards during equipment installation.

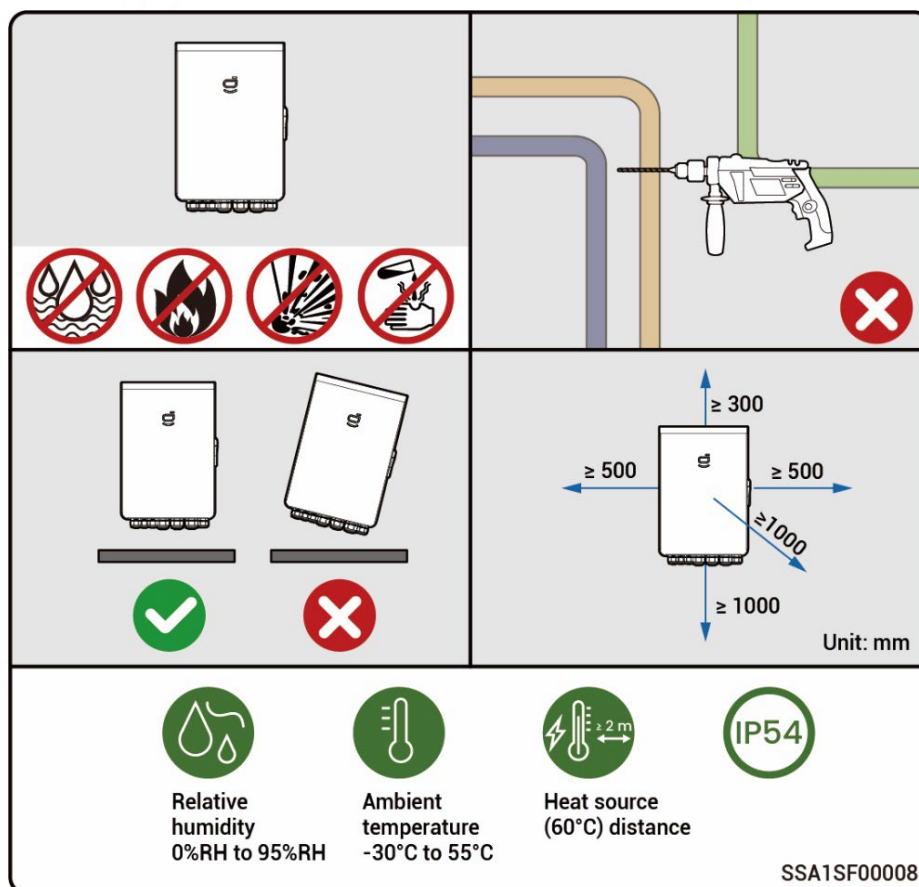

Chapter 4 Equipment Installation and Wiring

Only company authorized personnel should install and connect the equipment.
For details, see ***SiGen Gateway HomeMax TP Installation Guide***.

4.1 mySigen App Query

The App can be downloaded in the following two ways. For details, see **mySigen App User Manual**.

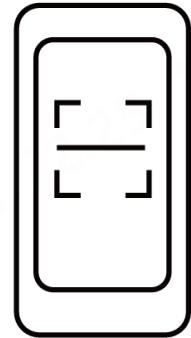

SSA1CM00014

Chapter 5 System Maintenance

5.1 Routine Maintenance

To ensure the long-term running of the equipment, you are advised to perform routine maintenance according to this section.

Inspection content	Inspection method	Power off or not	Maintenance cycle
System cleaning	Check the device regularly for shielding and dirt. If so, clean it up. Do not use tools that may cause electric shock or insulation damage, such as wire brushes and wet towels during the cleaning process.	Yes	Once every three months.
System running state	<ul style="list-style-type: none"> ● Check whether the equipment is damaged or deformed. ● Listen for any abnormal noises during the operation of the equipment. ● When the equipment is running, check whether the equipment parameters are correctly set. 	No	Once every six months.

5.2 Troubleshooting

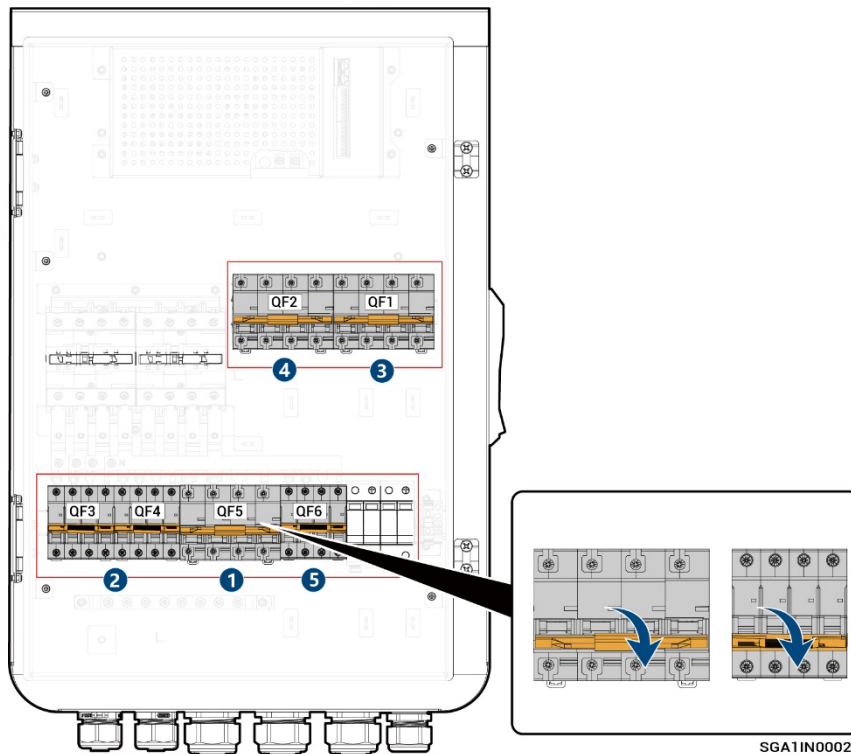

Warning

- If the device is abnormal, immediately switch off all the miniature circuit breakers and check the circuit. Switch them on again after the failure is removed.
- The Gateway should be disconnected in the following order:
 1. Switch off the miniature circuit breaker (Backup home loads) QF5 to disconnect the backup home loads from the equipment.
 2. Switch off the miniature circuit breakers (Inverter1, 2) QF3, QF4 to disconnect the inverter from the equipment.
 3. Switch off the miniature circuit breaker (Power grid) QF1 to disconnect the equipment from the power grid.
 4. (Optional) Switch off the miniature circuit breaker (Diesel generator) QF2 to disconnect the diesel generator from the equipment.
 5. Switch off the miniature circuit breaker (Surge protection device) QF6 to disconnect the surge protection device from the equipment.

5.3 Emergency Treatment

Emergency Measures for Fire

 **Danger**

- Please shut down the equipment or disconnect the main power switch when it is safe.
- If the fire is small, use carbon dioxide or ABC dry powder extinguisher to extinguish the fire.
- If the fire is spreading, evacuate the building or equipment area immediately and call the fire department. Re-entry to burning buildings is prohibited.
- Do not contact with high voltage components during fire fighting, otherwise it may lead to the risk of electric shock.
- After extinguishing the fire, do not use the equipment, please contact your installer.

Emergency Measures for Flood

 **Danger**

- Please shut down the equipment or disconnect the main power switch when it is safe.
- After the flood waters recede, do not use the equipment. Please contact your installer.

Chapter 6 Appendix

6.1 Technical Parameter

For details about equipment parameters, see the Data sheets of the product.