

Smart  
connections.

## Technical Information

PIKO MP plus

---

## Legal notice

KOSTAL Solar Electric GmbH  
Hanferstraße 6  
79108 Freiburg i. Br.  
Germany  
Phone +49 (0)761 477 44 - 100  
Fax +49 (0)761 477 44 - 111  
www.kostal-solar-electric.com

## Proper use

The inverter converts direct current into alternating current. This can be used as follows:

- For self-consumption
- For feed-in into the public grid

The device may only be used in grid-connected photovoltaic systems within the permissible power range and under the permissible ambient conditions. The device is not intended for mobile use.

Inappropriate use may lead to injury or even death for the user or third parties. Material damage to the device and other equipment can also occur. The inverter may therefore only be used for its intended purpose.

All components fitted on the inverter or in the PV system must satisfy the standards and guidelines that apply in the country of installation.

## Exclusion of liability

Any use that differs from that described under "Proper use" or goes beyond the stated intended purpose, is considered inappropriate. The manufacturer accepts no liability for any damage resulting from this. Modifications to the inverter are prohibited. The inverter may only be used if it is safe to operate and is in a technically perfect condition. Any instance of misuse will result in the termination of the warranty, guarantee and general liability of the manufacturer.

Only a qualified electrician may open the device. The inverter must be installed by a trained electrician (according to DIN VDE 1000-10 or BGV A3 accident prevention regulations or an internationally comparable standard) who is responsible for observing the applicable standards and regulations.

Work that could affect the electrical power system of the relevant energy supply company at the site of the solar power feed-in, may only be carried out by qualified electricians expressly authorised (licensed) by the energy supply company. This includes changes to the factory-preset parameters. The installer must always observe the regulations of the energy supply company.

Factory settings may only be changed by qualified electrical installers or persons with at least comparable or higher technical qualifications, e.g. foremen, technicians or engineers. When doing so, all requirements are to be observed.

## IMPORTANT INFORMATION

The inverter may only be installed, maintained and repaired by a trained and qualified electrician.

The electrician is responsible for ensuring that the applicable standards and regulations are observed and implemented. Work that could affect the electrical power system of the relevant energy supply company at the site of the solar power feed-in, may only be carried out by qualified electricians expressly authorised (licensed) by the energy supply company.

This includes changes to the factory-preset parameters.

## Table of contents

<b>1</b>	<b>General information .....</b>	<b>6</b>
1.1	Types.....	6
1.2	Accessories .....	6
1.3	Documents .....	6
1.4	Monitoring portal.....	6
1.5	Scope of delivery .....	7
1.6	Labelling .....	7
1.7	Type plate.....	8
1.8	EU Declaration of Conformity .....	8
1.9	Abbreviations.....	8
<b>2</b>	<b>Safety .....</b>	<b>9</b>
2.1	General safety instructions .....	9
2.2	Designated use.....	10
2.3	Target group .....	11
2.4	Labels and symbols.....	11
2.4.1	Safety marks.....	11
2.4.2	Keywords.....	12
2.5	Safety symbols on the device .....	12
<b>3</b>	<b>Structure and functioning.....</b>	<b>12</b>
3.1	Structure of the inverter .....	13
3.2	Connections.....	13
3.3	Operating buttons .....	14
3.3.1	Functions of the operating buttons.....	14
3.4	Display.....	15
3.5	Cooling .....	16
3.6	Grid monitoring .....	16
3.7	Data .....	16
3.7.1	Data communication .....	16
3.7.2	Data display.....	16
3.7.3	Data storage .....	17
3.8	Network (TCP/IP).....	17
3.9	"COM1" and "COM2" connections.....	17
3.9.1	Connecting further master devices .....	17
3.9.2	Connection of further inverters .....	18
3.9.3	Alternative RS485 data connecting cable .....	18
3.9.4	RS485 termination .....	19
3.9.5	RS485 addressing .....	19
3.9.6	Connecting an energy meter (Modbus RTU).....	20
3.9.7	Remote shutdown by the grid operator and rapid shutdown "Teledistacco" (Italy) .....	20
<b>4</b>	<b>Installing the inverter .....</b>	<b>21</b>
4.1	Safety instructions for installation .....	21
4.2	Mounting the inverter.....	23
4.2.1	Attaching the mounting plate .....	23
4.2.2	Fixing the inverter to the mounting plate.....	23

4.3	Preparing AC connection .....	23
4.3.1	Selecting AC cable .....	24
4.3.2	Residual current circuit breaker .....	24
4.3.3	Assembling the AC plug .....	25
4.4	Preparing DC connection.....	27
4.4.1	Fitting cable to DC plug .....	28
4.4.2	Preparing data connecting cable .....	28
4.5	Connecting battery to the inverter.....	29
4.6	Connecting inverter and switching AC on .....	30
4.7	Performing initial commissioning .....	31
4.8	Setting the feed-in management.....	31
4.8.1	Switching the energy meter on or off .....	31
4.8.2	Limiting the dynamic feed-in value.....	32
4.8.3	Selecting an energy meter .....	32
4.9	Switching DC on .....	32
<b>5</b>	<b>Initial commissioning.....</b>	<b>32</b>
5.1	Setting the display language.....	33
5.2	Setting the date and time .....	33
5.3	Setting the country.....	33
5.4	Setting the reactive power .....	34
5.4.1	Setting the mode.....	34
5.4.2	Changing parameters of the nodes.....	35
5.4.3	Displaying the reactive power characteristic curve .....	35
5.5	Finishing the initial commissioning.....	35
<b>6</b>	<b>Dismounting the inverter .....</b>	<b>36</b>
6.1	Switching AC and DC off .....	36
6.2	Disconnecting DC connection from inverter.....	36
6.3	Disconnecting AC plug from inverter .....	36
6.4	Opening the AC plug .....	37
6.5	Removing inverter from mounting plate .....	37
<b>7</b>	<b>Operation .....</b>	<b>38</b>
7.1	Menu structure.....	38
7.2	Navigating the menu structure.....	39
7.3	Status displays.....	39
7.3.1	Displaying output power .....	39
7.4	Main menu .....	40
7.4.1	Displaying yields.....	40
7.4.2	Generator characteristic curve.....	40
7.4.3	Event log.....	41
7.4.4	Information.....	41
7.4.5	Self-test (only Italy).....	42
7.4.6	Settings.....	43
7.4.7	Service.....	45
<b>8</b>	<b>Web portal .....</b>	<b>49</b>

---

<b>9</b>	<b>Fault elimination</b> .....	<b>50</b>
9.1	Event message type .....	50
9.2	Alerting behaviour.....	50
9.3	Operation.....	51
9.4	Event messages .....	51
<b>10</b>	<b>Maintenance and care</b> .....	<b>58</b>
10.1	Maintenance .....	58
10.2	Care.....	58
10.2.1	Removing dust.....	59
10.2.2	Cleaning .....	59
<b>11</b>	<b>Disposal</b> .....	<b>59</b>
<b>12</b>	<b>Technical data</b> .....	<b>60</b>
12.1	PIKO MP plus 1.5-1, 2.0-1, 2.5-1, 3.0-1 and 3.6-1.....	60
12.2	PIKO MP plus 3.0-2, 3.6-2, 4.6-2 and 5.0-2 * .....	62
<b>13</b>	<b>Table of countries</b> .....	<b>65</b>
<b>14</b>	<b>Liability, warranty</b> .....	<b>65</b>
<b>15</b>	<b>Contact</b> .....	<b>65</b>
<b>16</b>	<b>Annex</b> .....	<b>66</b>
16.1	Drilling pattern for wall mounting.....	66

## 1 General information

These instructions contain information for the safe use of the inverter and all the information that a specialist needs for setting up, and the operator needs for operating the inverter. When installing other components (e.g. PV generators, battery, wiring), follow the instructions of the respective manufacturer.

The PIKO MP plus inverters are available in various models for different power classes. The PIKO MP plus X.X-1 inverters are suitable for the connection to one PV generator or one battery. The PIKO MP plus X.X-2 inverters are suitable for the connection to two PV generators or one PV generator and one battery. The connection of a battery to the PIKO MP plus requires the use of the KOSTAL Smart Energy Meter and an activation code Battery. Both is available at our KOSTAL Solar web shop.

### 1.1 Types

The PIKO MP plus inverters are available in the following models:

- PIKO MP plus 1.5-1
- PIKO MP plus 2.0-1
- PIKO MP plus 2.5-1
- PIKO MP plus 3.0-1
- PIKO MP plus 3.0-2
- PIKO MP plus 3.6-1
- PIKO MP plus 3.6-2
- PIKO MP plus 4.6-2
- PIKO MP plus 5.0-2 (available as of Q2/2020)

### 1.2 Accessories

Ask for possible accessories, options, suitable PV generators, and installation material at the installer's or at KOSTAL Solar Electric GmbH.

### 1.3 Documents

Data sheets, country tables, and certificates are available in the download area of the KOSTAL Solar Electric GmbH homepage.

### 1.4 Monitoring portal

The "KOSTAL (PIKO) Solar Portal" monitoring portal of KOSTAL Solar Electric GmbH offers online monitoring of PV systems at no charge: [www.kostal-solar-portal.com](http://www.kostal-solar-portal.com)

## 1.5 Scope of delivery



- 1 Inverter
- 2 Mounting plate
- 3 AC plug

- 4 DC plug (one pair per DC connection)
- 5 Sealing cap (3 units)
- 6 Quick guide

## 1.6 Labelling

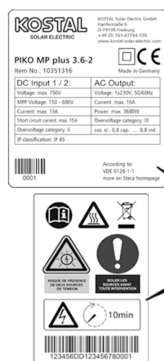

Type plate  
Safety marks



## 1.7 Type plate

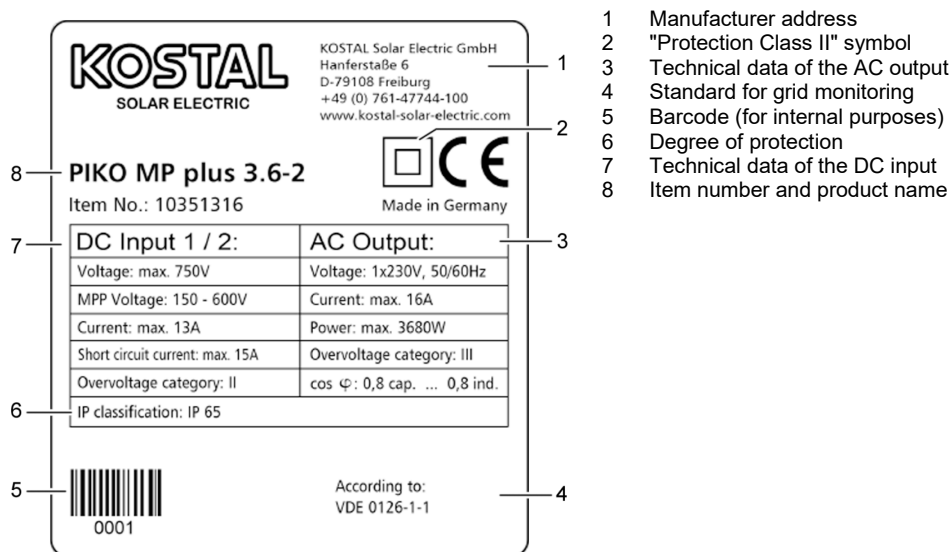

## 1.8 EU Declaration of Conformity

The products described in this document comply with the applicable European directives. Find the certificates on our website: [www.kostal-solar-electric.com/download](http://www.kostal-solar-electric.com/download)

## 1.9 Abbreviations

Abbreviation	Description
AC	Alternating Current
DC	Direct Current
DHCP	Dynamic Host Configuration Protocol (automatic connection of the device to an existing network)
DNS	Domain Name System (name of the IP address)
LAN	Local Area Network
MAC	Media Access Control (device address)
MPP	Maximum Power Point
MPP tracker	Regulates the power of the connected module strings to the MPP



Abbreviation	Description
MSD	<b>M</b> ains monitoring with allocated <b>S</b> witching <b>D</b> eVICES (internal grid monitoring of the inverter)
PV	<b>P</b> hotovoltaiCS (technology for the conversion of solar energy into electrical energy)
RTU	<b>R</b> emote <b>T</b> erminal <b>U</b> nit
SELV	<b>S</b> afety <b>E</b> xtra <b>L</b> ow <b>V</b> oltage
TCP/IP	<b>T</b> ransmission <b>C</b> ontrol <b>P</b> rotocol/ <b>I</b> nternet <b>P</b> rotocol
URL	<b>U</b> niform <b>R</b> esource <b>L</b> ocator (internet address)

## 2 Safety



### NOTE

Any repair work may only be carried out by the manufacturer's customer service department.

### 2.1 General safety instructions

- This document must be kept to hand at the site of use of the inverter.  
In case of a change of ownership pass on the document with the inverter.
- This document must have been read and understood in full before installing and using the inverter.
- Incorrectly connected components may cause damage to the inverter.
- If one of the following components is damaged, immediately take the inverter out of operation and disconnect it from the grid and the PV generators:
  - Inverter (not functioning, visible damage, smoke, penetration of liquid etc.)
  - Cables
  - PV generators
- Do not switch on the system again until it has been repaired and checked by a suitably qualified and authorised technical specialist.
- Dangerous voltages may be present for up to 10 minutes after disconnecting the inverter from the voltage sources.
- Disconnect inverter from both voltage sources (power grid and PV generator) prior to any work on the inverter.
- Always carry out the measures described in this document in the specified sequence.

- Do not change nor remove any factory-applied labels on the inverter.
- Do not open the inverter. Danger to life! Opening the inverter will also void any warranty.
- Do not cover the inverter.
- Keep children away from the inverter.
- Follow the instructions of manufacturers of the connected components.
- Follow the general and national safety and accident prevention regulations.



The inverter cannot cause a DC residual current due to its design.

## 2.2 Designated use

The PIKO MP plus inverters are intended for single-phase feed-in and are suitable for indoor and outdoor (degree of soiling 3) installation. The inverters are designed for wall mounting.

- Only use the inverter for grid-connected PV generators.
- The inverter is suitable for PV generators whose connections are not grounded.
- All connected solar modules must be classified as Class A according to IEC 61730, because these inverters do not have galvanic isolation.
- The maximum permissible system voltage of the PV generator must be higher than the AC grid voltage.
- The installation location for the inverter must not be at an altitude higher than 2000 m above MSL.
- Only approved batteries may be connected to the inverter.



### NOTE

Only for Italy: information about the particularities for the use in Italy have been added to the Italian version of the installation and operating instructions.

## 2.3 Target group





Unless otherwise noted, the target group for these instructions are specialists and system operators. The following persons are considered specialists:

- Persons that have knowledge of the established terms and skills for setting up and operating PV systems.
- Persons that due to their knowledge and experience are able to evaluate the following tasks and recognise possible hazards:
  - Mounting electrical equipment
  - Assembling and connecting data cables
  - Assembling and connecting power supply cables

## 2.4 Labels and symbols

### 2.4.1 Safety marks

The following safety marks are used on the inverter and in these instructions:

Warning sign	Nature of the danger
	Warning of hazardous voltage
	Warning of hazardous area
	Warning of hot surface
	Follow the instructions
	Disposal information (separate collection of electrical and electronic equipment)

## 2.4.2 Keywords

The following keywords are used in these instructions:

Keyword	Meaning
<b>DANGER</b>	Indicates a hazardous situation which, if not avoided, leads to death or serious injuries.
<b>WARNING</b>	Indicates a potentially hazardous situation which, if not avoided, may lead to death or serious injuries.
<b>NOTE</b>	Indicates a potentially hazardous situation which, if not avoided, may lead to damage to property and/or the environment.

## 2.5 Safety symbols on the device



- 1 Disposal information (separate collection of electrical and electronic equipment)
- 2 Request to disconnect the power sources prior to any intervention
- 3 Information on presence of voltage after switching off the inverter
- 4 Serial number (barcode and plain text)
- 5 Warning of voltage (two voltage sources)
- 6 Warning of hot surface
- 7 Follow the instructions

## 3 Structure and functioning

The PIKO MP plus inverter is connected between PV generators and consumers. Via the DC input and the MPP tracker, PV generators feed in DC, which the inverter converts into AC. Consumers connected to the AC connection are supplied AC by the inverter.

### 3.1 Structure of the inverter

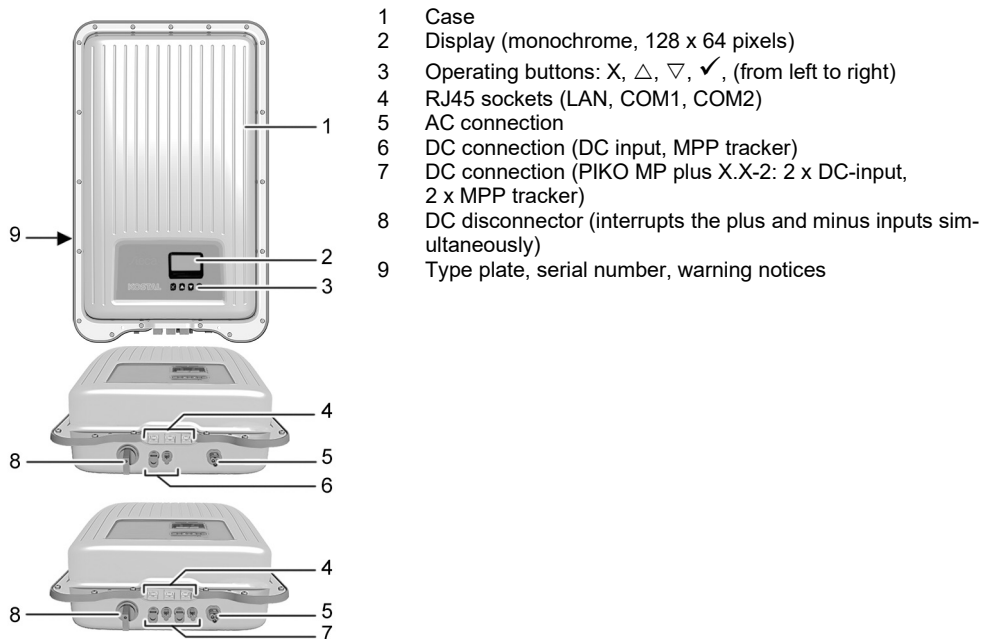

### 3.2 Connections

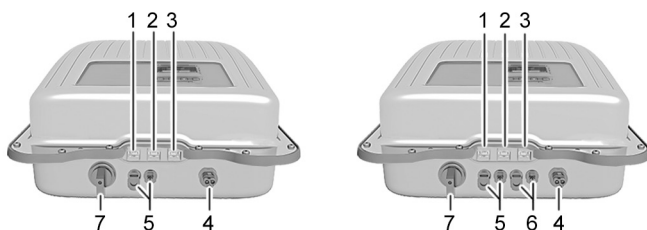

- 1 TCP/IP connection (LAN)
- 2 RS485 connection (COM1)
- 3 Modbus RTU connection (COM2)
- 4 AC connection

- 5 DC connection
- 6 DC connection (PIKO MP plus X.X-2)
- 7 DC disconnector

### 3.3 Operating buttons

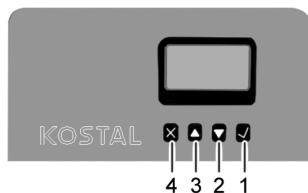

- 1 ✓ (SET)
- 2 ▾
- 3 ▴
- 4 X (ESC)

#### 3.3.1 Functions of the operating buttons

Button	Action	Function	
		Normal operation	Commissioning
X	Press briefly	<ul style="list-style-type: none"> <li>- Jumps 1 menu level up</li> <li>- Discards changes</li> </ul>	Jumps 1 step back
	Press longer (≥ 1 second)	Jumps to the start image	Jumps to the start of the guided operation
▴	Press briefly	<ul style="list-style-type: none"> <li>- Moves the selection bar or the display content upwards</li> <li>- Moves the selection bar 1 position to the left when setting numeric values</li> <li>- Increases the setting value by 1 step</li> </ul>	
		Browses in menu structure	-
	Press longer (≥ 1 second)	Triggers a repetition of the command. The repetition rate increases when pressing for a longer period	
▾	Press briefly	<ul style="list-style-type: none"> <li>- Moves the selection bar or the display content downwards</li> <li>- Moves the selection bar 1 position to the right when setting numeric values</li> <li>- Decreases the setting values by 1 step</li> </ul>	
		Browses in menu structure	-
	Press longer (≥ 1 second)	Triggers a repetition of the command. The repetition rate increases when pressing for a longer period	

Button	Action	Function	
		Normal operation	Commissioning
✓	Press briefly	<ul style="list-style-type: none"> <li>- Jumps down by 1 menu level</li> <li>- Jumps to the diagram view in certain menus</li> </ul>	-
		<ul style="list-style-type: none"> <li>- A selected value starts flashing and can be changed</li> <li>- Accepts any entered changes</li> <li>- Changes the state of a control element (check box / radio button)</li> </ul>	
	Press longer (≥ 1 second)	Answers a query dialogue with Yes	Navigates 1 step forward

### 3.4 Display



At very low temperatures, the display may respond more slowly than usual.

The display shows the menus of the inverter (for an overview of the menus refer to section 7.1).

As a general rule, the menu name is located in the top left corner, and the corresponding values or selection lines underneath.

The backlight of the display is switched on by pressing any button. The operating states of the inverter are shown as follows:

Display	Meaning
	The inverter is processing large data volumes. It is not possible to enter user data
Backlight flashing red with event message	Fault

## 3.5 Cooling

The inverter may heat up during operation. This is a normal operating characteristic.

When the internal temperature rises above a certain value, an internal temperature controller regulates the power consumption from the PV generator. The operating temperature decreases when power consumption is lower.

A fan disperses the waste heat inside the closed case evenly onto the case surface. Cooling fins allow the heat to dissipate to the surrounding.

## 3.6 Grid monitoring

The grid monitoring in the device permanently monitors the grid parameters of the public grid. If the grid monitoring detects a deviation of the grid parameters from the statutory requirements, the device switches off automatically. When the public grid meets the statutory requirements again, the device switches on again automatically.

## 3.7 Data

### 3.7.1 Data communication

The device has the following communication interfaces:

- "LAN" connection ( Ethernet for TCP/IP network) for the communication with a central data server
- "COM2" connection (Modbus RTU) for the communication with e.g. an external energy meter
- "COM1" connection (RS485 bus) for the communication with external devices, e.g. with a data logger (for the PIKO MP plus X.X-2: two connections) or, in battery mode, for the connection of the KOSTAL Smart Energy Meter

For data analysis purposes, the inverter can provide a wide range of data via the RS485 and LAN interfaces (e.g. data logger). The RS485 bus also allows the connection to other inverters.

### 3.7.2 Data display

The following data are shown on the display:

- voltage and current generated by the PV generator
- power and current fed into the public grid
- current voltage and frequency of the public grid
- generated energy yields on a daily, monthly and annual basis
- current error states and notes
- information about the version of the device
- in the battery mode: SOC, battery voltage, as well as charge and discharge current



### 3.7.3 Data storage

In the internal memory (EEPROM), event messages and energy yields are stored with the date. The energy yields are stored for the specified period.

Energy yield	Storage resolution/period
10-minutes values	31 days
Daily values	13 months
Monthly values	30 years
Annual values	30 years
Total yield	Permanent

## 3.8 Network (TCP/IP)

Via the "LAN" connection, the device can send yield data and event messages to the server of a web portal. The KOSTAL (PIKO) solar portal ([www.kostal-solar-portal.com](http://www.kostal-solar-portal.com)) allows the graphical representation of the yield data.

In "Settings" > "Network", the operator can enter the network parameters in further sub-menu masks (refer to section 7.4.6).

## 3.9 "COM1" and "COM2" connections

The inverter can communicate with other device via the "COM1" and "COM2" connections. Requirements for the communication:

- Both ends of the data connection are terminated.
- RJ45 standard cables or alternative data connecting cables are used as bus cables.

### 3.9.1 Connecting further master devices



Set an external data logger prior to the connection. Follow the instructions of the manufacturers.

Optionally, **one** of the following master devices can be connected to the "COM1" connection. These devices support the transfer protocol of the inverter.

- KOSTAL Smart Energy Meter
- External data logger for professional system monitoring (refer to document "Kompatible Partner/Compatible partner", which can be found in the download area for the product)

### 3.9.2 Connection of further inverters

Inverters connected via the "COM2" connection operate as slave devices. RJ45 standard cables (patch cables) for outdoor installation are suitable connecting cables.



The following inverters have compatible data interfaces and can be connected as slaves to the "COM1" and "COM2" connections:

- PIKO 1.5, 2.0, 2.5, 3.0, 3.6, 4.2 MP
- PIKO MP plus 1.5-1, 2.0-1, 2.5-1, 3.0-1, 3.0-2, 3.6-1, 3.6-2, 4.6-2, 5.0-2

Follow the instructions on addressing, termination, and approved data cables in the operating instructions of these devices.



- |   |                      |   |                                   |
|---|----------------------|---|-----------------------------------|
| 1 | External data logger | 4 | Last inverter, terminated         |
| 2 | First inverter       | 5 | RJ45 standard cable (patch cable) |
| 3 | Inverter             |   |                                   |

### 3.9.3 Alternative RS485 data connecting cable



#### NOTE

Voltage may cause property damage.

- ▶ Only have specialists manufacture the alternative data connecting cable.

Use a CAT 5 cable for the alternative data connecting cable in the case of long data connecting distances.

The total length of the data connecting cable shall not exceed 1000 m.

If the alternative data connecting cable is connected to the RJ45 socket of the first inverter and to the connection of the external data logger, the connections in the plug must be assigned in accordance with the following table.

Pin assignment of alternative RS485 data connecting cable for external data loggers or for the connection of further inverters.

Device	Signal	Inverter
Connection	↓	COM1/COM2
Contact	Data A	1
	Data B	2
	Ground	8

Connection KOSTAL Smart Energy Meter for battery control:

Device	Signal	Inverter	KSEM
Connection	↓	COM1	RS485 (B)
Contact	Data A	1	3
	Data B	2	4
	Ground	8	2



#### NOTE

Contact 1 of the RJ12 socket supplies 24 V DC!

The RS485 input of the inverter may be damaged.

- ▶ Never connect the alternative data connecting cable to contact 1.

### 3.9.4 RS485 termination

Terminate the data connection at its beginning and at its end to ensure faultless data transmission:

- Beginning of the data connection: terminate external data logger in accordance with the manufacturer's instructions.
- End of the data connection: insert termination plug into the vacant RS485 interface of the last inverter.

### 3.9.5 RS485 addressing

All inverters are set to address "1" at the factory. For the master-slave communication, each inverter requires its own address. The address is changed in the menu under "Settings" > "RS485 address".

- If possible, assign the addresses starting with 1 at the first inverter and ascending to the last, as the number of possible addresses in the inverters is limited.
- The sequence of addresses should mirror the order of the mounted devices, to facilitate the identification of the devices.

### 3.9.6 Connecting an energy meter (Modbus RTU)

The inverter is able to communicate with energy meters via the "COM2" connection. To do this, the energy meter must meet the following requirements:

- The energy meter has been preprogrammed in the inverter. The current list can be found in [www.kostal-solar-electric.com/download](http://www.kostal-solar-electric.com/download) > PIKO MP plus > Model > Country > Operating manual > Approved energy meters.
- The energy meter measures the draw from the grid in positive direction (refer to instructions of the energy meter).

#### Modbus RTU data connecting cable



#### NOTE

Voltage may cause property damage.

- ▶ Only have specialists manufacture the alternative data connecting cable.

Use a RJ45 standard cable or a CAT5 patch cable as data connecting cable.

#### Plug connection of the Modbus RTU data connecting cable

The connection of the external energy meter KOSTAL Smart Energy Meter (KSEM) is described in the operating instructions "KOSTAL Smart Energy Meter". The connection of other approved external energy meters is described in the operating instructions "PIKO MP plus Energiezähler / Energy meters". Both documents can be found in our download area.

Connection KOSTAL Smart Energy Meter for load/generation measurement:

Device	Signal	Inverter	KSEM
Connection	↓	COM2	RS485 (B)
Contact	Data A	6	3
	Data B	7	4
	Ground	8	2

### 3.9.7 Remote shutdown by the grid operator and rapid shutdown "Teledistacco" (Italy)



This configuration meets both the requirements in accordance with **VDE-AR-N-4105** and the requirements for a **rapid shutdown ("Teledistacco") for Italy in accordance with CEI 0-21**.



To allow a rapid shutdown of the generating plant by the grid operator (RAPID SHUTDOWN) via an external device used for control purposes, the connections "COM1" or "COM2" must be connected as described below.

### Assignment of contacts for rapid shutdown



Assignment of contacts corresponds to the conductor number of the RJ45 plug.

For external fast shutdown, lines 3 and 8 of COM1 or COM2 are connected (e.g. with an external relay). The following applies:

- **Relay closes:** Inverters connected to the bus disconnect from the grid.
- **Relay opens:** Inverters connected to the bus connect to the grid in normal operation.

## 4 Installing the inverter

### 4.1 Safety instructions for installation



#### **DANGER**

Voltage

Under solar radiation, the PV generators and cables may be energised. There is the risk of death due electrocution and electric discharge.

- ▶ Disconnect the DC and AC connections from the power source prior to any work on the inverter:
  - Switch off all AC line circuit breakers and secure them against being switched on again.
  - Set the DC disconnecter on the inverter to position '0' and secure it against being switched on again.
  - Disconnect the plugs of the DC cables (follow the instructions of the manufacturer).
  - Disconnect AC plug from the inverter: press locking hook on the AC plug slightly and remove AC plug.
- ▶ Only have specialists carry out any installation work.
- ▶ Only connect the cables to the inverter when it is requested by the instructions.
- ▶ Only connect SELV circuits to the RJ45 socket.

**NOTE**

Improper installation may cause performance reduction or damages on the inverter.

- ▶ Ensure that the installation site meets the following requirements:
  - The mounting surface and immediate surrounding must be: permanently fixed, vertical, level, of low flammability, and not subject to constant vibration.
  - The ambient conditions are within the permissible range (refer to chapter 12).
  - Open spaces are provided for around the device (above and underneath  $\geq 200$  mm, to the sides and in front  $\geq 60$  mm).
- ▶ Do not install the device in stables where animals are kept.
- ▶ Avoid exposure to direct sunlight of the device.
- ▶ Ensure that the display can be easily read on the installed device.



Data transmitted via a public network are not protected from being accessed by third parties.

Data transmission via a public network may cause additional costs.

- ▶ Obtain information on costs possibly involved prior to the use of a public network.
- ▶ Use a public network at your own risk.

A type A residual current breaker (RCCB) is sufficient.

- Lay the cables such that the connection cannot come loose accidentally.
- Ensure that the fire safety measures of the building are not impaired when routing cables for the device.
- Make sure that no inflammable gases are present.
- Observe all applicable installation regulations and standards, national laws and connection values specified by the regional power supply company.
- Observe the connection ratings specified on the type plate.
- Do not connect the DC cables to ground potential.  
The DC inputs and the AC output are not galvanically isolated from each other.

## 4.2 Mounting the inverter

### 4.2.1 Attaching the mounting plate

1. Place mounting plate on the mounting surface. The locking plate (1) must point upwards. The retaining tabs point to the front.
2. Fasten the mounting plate to the mounting surface with 4 screws. For the drilling pattern refer to chapter 16.

The mounting materials are not included in the scope of delivery.

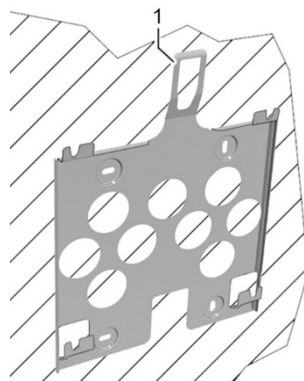

### 4.2.2 Fixing the inverter to the mounting plate

1. Place inverter centrally on the mounting plate. In doing so, hold the inverter by the edge (1).
2. Slightly press on the inverter and slide it downwards. The locating pins (4) on the inverter must hook into the retaining tabs on the mounting plate.
3. Introduce detent (2) into the opening of the locking plate (3). When the detent audibly click into place, the device can no longer be lifted.

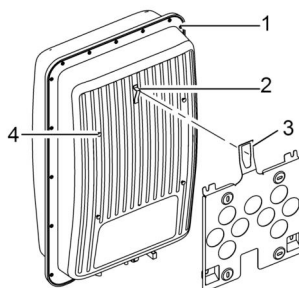

## 4.3 Preparing AC connection



### **DANGER**

Voltage

There is a risk of death by electrocution.

- ▶ Follow the safety instructions and warning notices in section 4.1.

### 4.3.1 Selecting AC cable

Install the circuit breaker prior to any work on the AC connection.

Depending on the power of the inverter, you may have to use different circuit breakers and connecting cables.

Inverter	Cable cross section AC cable	Power loss (with 10 m cable length)	Circuit breaker
PIKO MP plus 1.5-1	1.5 mm <sup>2</sup>	10 W	B16
	2.5 mm <sup>2</sup>	6 W	
	4.0 mm <sup>2</sup>	4 W	
PIKO MP plus 2.0-1	1.5 mm <sup>2</sup>	18 W	B16
	2.5 mm <sup>2</sup>	11 W	
	4.0 mm <sup>2</sup>	6 W	
PIKO MP plus 2.5-1	2.5 mm <sup>2</sup>	16 W	B16
	4.0 mm <sup>2</sup>	11 W	
PIKO MP plus 3.0-1 PIKO MP plus 3.0-2	2.5 mm <sup>2</sup>	25 W	B16 or B25
	4.0 mm <sup>2</sup>	15 W	
PIKO MP plus 3.6-1 PIKO MP plus 3.6-2	2.5 mm <sup>2</sup>	35 W	B25
	4.0 mm <sup>2</sup>	23 W	
PIKO MP plus 4.6-2	2.5 mm <sup>2</sup>	56 W	B25
	4.0 mm <sup>2</sup>	35 W	
PIKO MP plus 5.0-2	2.5 mm <sup>2</sup>	64 W	B25
	4.0 mm <sup>2</sup>	40 W	

### 4.3.2 Residual current circuit breaker

If the local installation specifications prescribe the installation of an external residual current circuit breaker, install a residual current circuit breaker. In accordance with IEC 62109-1, a type A residual current circuit breaker is adequate.



### 4.3.3 Assembling the AC plug



#### NOTE

If the instructions of the plug manufacturer are not followed when connecting the AC plug, the cable and the device may be damaged.

- ▶ Follow the instructions of the plug manufacturer.

Assemble the AC plug (refer to section "Assembly instruction for AC plug") and connect it.

#### 220 V to 240 V grid voltage

Connect conductors N, L, and PE on the AC plug in 1-phase grid with 220 V to 240 V grid voltage.

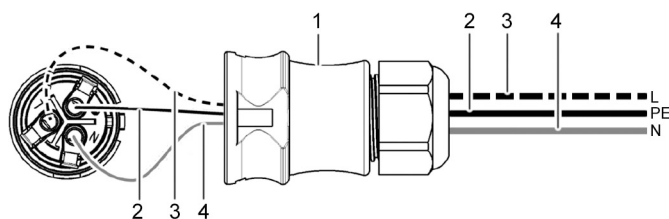

- 1 AC plug housing
- 2 PE connection

- 3 L connection (outer conductor)
- 4 N connection (outer conductor)

#### 100 V to 127 V grid voltage



#### DANGER

Voltage

There is a risk of death by electrocution when connecting the phases L1, L2, or L3 to PE or N.

- ▶ Follow the safety instructions and warning notices in section 4.1.

The structure of 100 V to 127 V grid voltages differs from that of 220 V to 240 V grid voltages as it is not a 1-phase but a 2 or 3-phase grid.

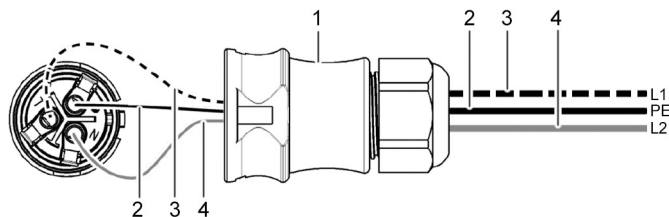

- 1 AC plug housing
- 2 PE connection

- 3 L1 connection (outer conductor)
- 4 L2 connection (outer conductor)

### Connecting AC plug to 2-phased grid

Connect the inverter between the L1 and L2 outer conductors.

1. Connect the N and L connection of the AC plug (1) between the L1 (3) and L2 (4) outer conductors of the grid cable.
2. Connect PE cable to PE connection on the AC plug.

### Connecting AC plug to 3-phased grid (not depicted)

In the 3-phase grid, there are 3 outer conductors in the cable:

1. Connect N and L connections of the AC plug between any 2 outer conductors (between L1 and L2, or L1 and L3, or L2 and L3).
2. Connect PE cable to PE connection on the AC plug.

### Voltage distribution in the 2 and 3-phase grid

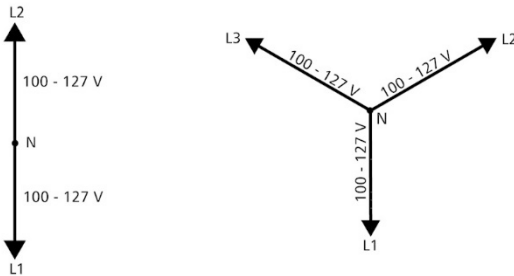

The voltage in 2 and 3-phase grids is the same in every outer conductor: 100 V to 127 V.

## Assembly instruction for AC plug

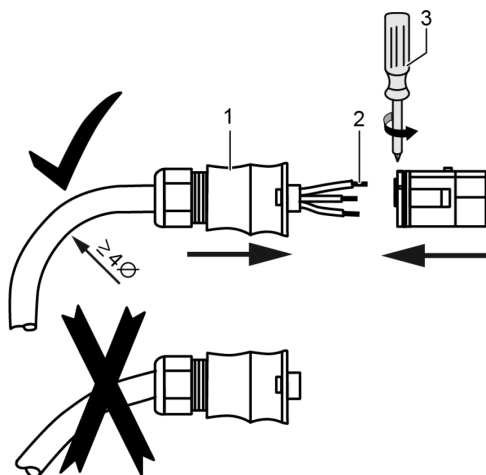

1. Guide cable through the plug housing. Slide plug housing (1) onto the cable.
2. Introduce wire ends (2) into the plug. Ensure that the bending radius of the cables is large enough (at least 4 times the cable diameter).
3. Using a screwdriver (Pozidriv PZ1) (3), secure wire ends with clamping screws. Tightening torque: 0.8 to 1 Nm. Ensure that the clamping connection holds.
4. Slide plug housing onto the plug and tighten until a click sound is heard.

## 4.4 Preparing DC connection



### DANGER

Voltage

There is a risk of death by electrocution.

- ▶ Follow the safety instructions and warning notices in section 4.1.
- ▶ Use the SUNCLIX plug connectors (DC plugs) included in the scope of delivery to ensure the specified degree of protection.



### NOTE

If the DC plugs are not connected correctly to the DC cable, there is a risk of short circuit. The inverter and modules may be damaged.

- ▶ Connect counterparts to the DC connections to the DC cable ensuring correct polarity.

### 4.4.1 Fitting cable to DC plug



#### NOTE

Soiled, displaced, or damaged seals impair the strain relief and the impermeability.

- ▶ Do not soil, shift, nor damage the seals during DC plug assembly.

1. Strip 15 mm of cable end of cable (1).

2. Release spring (2) upwards.

3. Introduce stripped cable end into the DC plug until the cable end becomes visible underneath the spring (2).

4. Press spring (2) against the stripped cable end until it engages audibly. Ensure that the cable end is securely fastened.

5. Slide union nut (4) onto inset (3) of the DC plug.

6. Hold inset with a size 16 wrench and tighten the union nut (4) with a wrench, applying a tightening torque of 2 Nm.

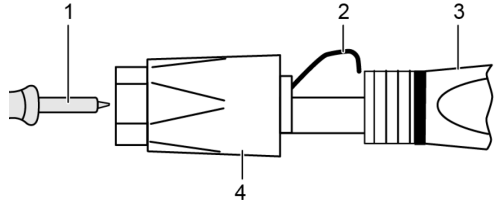

### 4.4.2 Preparing data connecting cable

You can use a standard cable (patch cable, CAT5) suitable for outdoor operation or an alternative RS485 data connecting cable for the data connection. Observe section 3.9.3 when manufacturing an alternative data connecting cable.

## 4.5 Connecting battery to the inverter

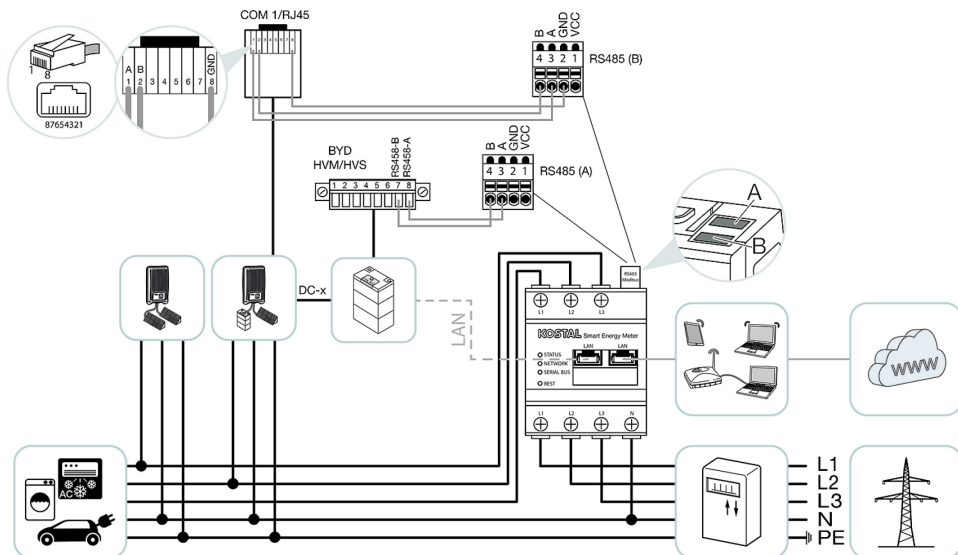

Depending on the type of device, a battery can be connected to the DC1 or DC2 connection on the PIKO MP plus. In addition to the battery, this requires a KOSTAL Smart Energy Meter and also an activation code Battery, which must be entered in the KOSTAL Smart Energy Meter.

The communication and control of the battery and the inverter (charging/discharging) takes place via the KOSTAL Smart Energy Meter. Therefore, both device must be set up in the KOSTAL Smart Energy Meter. Information about this can be found in the operating instructions of the KOSTAL Smart Energy Meter.

In the PIKO MP plus, the DC connection to which the battery is connected to must be selected in the menu "Settings" > "Service" > "Input". Selecting the energy meter in the PIKO MP plus and the installation position (only one grid connection point is admitted) is not required.

Both devices (PIKO MP plus and battery) must be entered and configured in the KOSTAL Smart Energy Meter.

The battery can be connected to the following DC connections:

PIKO MP plus	DC1	DC2	Battery
PIKO MP plus X.X-1	X	--	X
PIKO MP plus X.X-2	--	X	X



A list of the approved batteries for the PIKO MP plus can be found in the download area for the product on our homepage [www.kostal-solar-portal.com](http://www.kostal-solar-portal.com).

**DANGER**

Voltage

There is a risk of death by electrocution.

- ▶ Follow the safety instructions and warning notices for battery and energy meter.
- ▶ The communication cable may only be connected if all devices are free of voltage. Follow the operating instructions of the manufacturers.

1. Disconnect in-house grid and battery storage from voltage.
2. Lay the communication cable from the inverter and battery storage to the KOSTAL Smart Energy Meter and connect it to the intended interface on the KOSTAL Smart Energy Meter. The installation and configuration are described in the operating instructions for the KOSTAL Smart Energy Meter, refer to [www.kostal-solar-electric.com/download](http://www.kostal-solar-electric.com/download) > Accessories > KOSTAL Smart Energy Meter > Country > Operating manual.
3. Connect DC cables of the battery to the PIKO MP plus.
4. After installing the inverter, change DC connection to which the battery is connected to Battery in the inverter, in the menu "Settings" "Service" > "Inputs" > "DCx".
5. Check the RS485 address of the inverter for later setup in the KOSTAL Smart Energy Meter (in the menu "Settings" > "RS485 address").

## 4.6 Connecting inverter and switching AC on

**DANGER**

Voltage

There is a risk of death by electrocution.

- ▶ Follow the safety instructions and warning notices in section 4.1.



DC and AC cables may interfere with data transmission.

- ▶ Keep a distance of 200 mm between the data connecting cables (RS485/Ethernet) and the DC/AC cables.

**NOTE**

If sealing caps are missing, moisture may get into the inverter.

- ▶ Seal vacant RJ45 sockets with sealing caps.

1. If required, establish the data connection:
  - Connect inverters (mater device and further connected inverters) with data connecting cable(s).
  - Switch on termination on the last inverter (slide switch).
2. Seal vacant RJ45 sockets with sealing caps.
3. Press DC plug firmly into the DC connection in the inverter until it engages audibly.
4. Insert AC plug into the AC connection in the inverter until it engages audibly.
5. Switch on the AC circuit breaker.

The display shows the start page of initial commissioning.

## 4.7 Performing initial commissioning

Any further actions required for the installation of the inverter cannot be carried out before the initial commissioning has been performed. The initial commissioning is comprehensibly described in chapter 5.

## 4.8 Setting the feed-in management

Depending on the country, the active power on the connection point must be limited to a maximum value. The following products are suitable for implementing this legal requirement:

- KOSTAL Smart Energy Meter
- Other approved energy meters (refer to the document "PIKO MP plus Energiezähler / Energy meters", which can be found in the download area for the product)

An energy meter can be connected to the inverter via the Modbus RTU interface (refer to section 3.9.6) and, thus, the inverter takes over the control by itself.

The feed-in management is set in the "Energy management" submenu (refer to section 7.1).

- "Mode": switching the energy meter on or off
- "Dyn. feed in control": limiting the value of feed-in
- "Configuration": selecting an energy meter

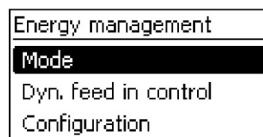

### 4.8.1 Switching the energy meter on or off

- "Off": switching the energy meter off
- "Energymeter": switching the energy meter on

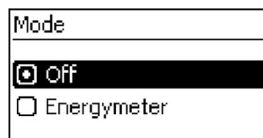

## 4.8.2 Limiting the dynamic feed-in value

1. Limit the power fed into the grid. You can enter values starting from 0 W and incrementing by 10 W.



## 4.8.3 Selecting an energy meter

The inverter can only communicate with the energy meters that have been preprogrammed.

1. Call the "Metertype" menu by pressing "✓".
2. Using "△ ▽", select a meter type from the list of preprogrammed energy meters.
3. Exit the menu with "X".

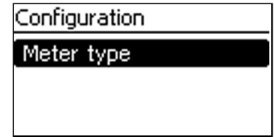

## 4.9 Switching DC on

Switching on the DC disconnecter on the inverter finishes the installation of the inverter. After approx. 2 minutes, the display can show the fed-in power (provided that there is solar radiation).

If a battery is used: first, switch on battery and wait until the battery has started up.

1. Turn DC disconnecter on the inverter to position 'I'.

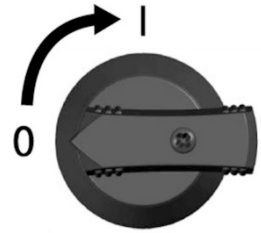

## 5 Initial commissioning

After installing and switching on the inverter, the dialogue for initial commissioning starts automatically. During initial commissioning, the user will navigate through the menu structure via the display.

If the initial commissioning is not completed, the dialogue for initial commissioning will start again after switching on the inverter.

During initial commissioning, you will set the display language, the date, the time, the country, and the reactive power characteristic curve (only when prescribed for the selected country).

A checklist with all the settings required for the initial commissioning is shown on the display.



Not until all the checkboxes in the checklist have been marked and the "Finish" menu is closed, will the initial commissioning be concluded.



The settings in the menus of the initial commissioning are performed via the operating buttons (for a comprehensive description of the function of the operating buttons, refer to section 3.3).

1st commissioning

- Language
- Date format
- Date

## 5.1 Setting the display language

The default display language is English.

1. Select and confirm the desired language.

Language

- english
- deutsch
- français

## 5.2 Setting the date and time

1. Select and confirm the desired date format.
2. Set and confirm date/time. The inverter will automatically correct any invalid input.

Date format

- JJJJ-MM-TT
- TT.MM.JJJJ
- MM/TT/JJJJ

Date setting

20.07.2011

## 5.3 Setting the country

With this menu item, you will set the country of use. Depending on the selection, the inverter will load the grid parameters specified for the country (refer to "Table of countries" in the download area related to the product: [www.kostal-solar-electric.com/download](http://www.kostal-solar-electric.com/download)).

The country can only be set once. In case of an incorrect input or change of country:

1. Please contact KOSTAL Solar Electric GmbH (ask for password).
2. In the "Del. country settin" menu, delete the set country (password-protected setting).
3. Perform the initial commissioning again.

If the respective country is not present in the country selection, select a country with stricter specifications.

The selection of a country has no impact on the display language.

1. Select and confirm the country.
2. If a correction is required, return to the country selection mask by pressing "X".
3. If the input is correct, confirm the set country (press "✓" longer).

Country code sel.

- 03400 Espana
- 04400 United Kingdom
- 04600 Schweden

## 5.4 Setting the reactive power



The "Reactive power" menu only appears when in the selected country a reactive power setting is prescribed.



The data for the reactive power control are not indicated in the consumer counting arrow system but in the generator counting arrow system.

In the "Reactive power" menu, you can set the reactive power mode and display the reactive power characteristic curve.

### 5.4.1 Setting the mode

1. Select and confirm the "Mode" menu.

Reactive power

Mode

Display curve

2. Select and confirm the desired mode. The "Reactive power" menu is displayed again.

Mode

cosPhi = 1

Q(P)

Q(U) lin.

If another mode than "cosPhi = 1" has been selected, the display in the "Reactive power" menu will additionally show the "Load Defaults" and "Number of nodes" menu items. In this case, additionally perform the following actions:

3. Select and confirm the "Load Defaults" menu.

Reactive power

Mode

Load Defaults

Number of nodes

4. Select the desired defaults and confirm with "✓". The "Reactive power" menu is displayed again.

Load Defaults

Q(P) >3680W

Q(P) >13800W

5. Select and confirm "Number of nodes".

6. Enter and confirm the number of nodes. The characteristic curve is freely programmable through the nodes.

Set reactive power

Enter no. of nodes

**4**

7. With "X" continue to the "Nodes" menu (for > 2 nodes) or go back to the "Reactive power" menu (for ≤ 2 nodes).

## 5.4.2 Changing parameters of the nodes

The "Nodes" menu mask only appears when at least 3 nodes have been entered.

1. Enter and confirm the desired value for "P" and "cos  $\psi$ ".
2. Return to the "Reactive power" menu with "X".



"P (%)" cannot be changed for the first and the last node (000 %, 100 %).

## 5.4.3 Displaying the reactive power characteristic curve

The characteristic curve previously entered is displayed.

1. Return to the checklist with "X".

## 5.5 Finishing the initial commissioning

1. Select "Finish" from the checklist and confirm.

If the checklist has not been processed completely, the message "Settings are incomplete" is displayed. In this case:

1. Press "✓". The checklist is displayed again.
2. Process the open items and finish the processing.

When all settings have been processed, a dialogue stating "Are all settings correct?" is displayed. In this case:

1. Check the settings.
2. If any settings have to be corrected, select the corresponding menu in the checklist and correct the settings.
3. If all the settings are correct: press "✓" longer. The inverter is restarted and synchronises itself with the grid.

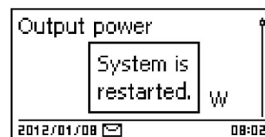

After finishing the initial commissioning, you can set the feed-in management and switch DC on (refer to section 4.8).

## 6 Dismounting the inverter

The safety instruction from section 4.1 apply.

### 6.1 Switching AC and DC off

1. Turn DC disconnecter on the inverter to position "0".
2. Switch the AC circuit breaker off.

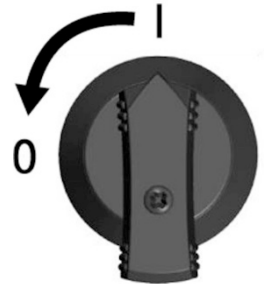

### 6.2 Disconnecting DC connection from inverter



#### **DANGER**

Voltage can be present at the DC-connection for up to 10 minutes after switching off the DC circuit breaker.

There is a risk of death by electrocution.

- ▶ Wait 10 minutes after switching off the DC disconnecter.



#### **DANGER**

The PV generator carries voltage when there is solar radiation.

There is a risk of death by electrocution.

- ▶ Only have specialists carry out any work on the DC connection.

1. Disconnect plug of the DC cables as described in the instructions of the DC plug manufacturer.

### 6.3 Disconnecting AC plug from inverter

1. Using a suitable tool, press locking hook on the AC plug slightly in and remove the plug.
2. Ensure that none of the AC plug poles carries voltage with the help of a suitable voltage tester (do not use a phase testing probe).

## 6.4 Opening the AC plug

1. Open the rear cable gland.
2. Simultaneously press in the locking hooks on the left and on the right of the plug housing with a suitable tool.
3. Remove the upper part of the housing from the contacting part.

## 6.5 Removing inverter from mounting plate

1. Press locking plate (3) towards the wall and hold it there.
2. Push inverter upwards until the detent (2) can no longer snap in.
3. Release the locking plate.
4. Hold inverter by the edge (1) with both hands and lift it off upwards. The locating pins (4) must separate from the retaining tabs of the mounting plate.
5. Remove inverter from mounting plate.
6. Unscrew the fastening screws of the mounting plate.
7. Remove mounting plate.

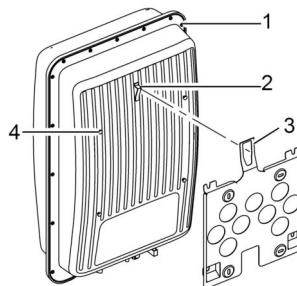

# 7 Operation

## 7.1 Menu structure

The menu structure of the inverter is divided into **Status display**, the **Main menu** and **Submenus**, which themselves may contain further submenus.

When switching on the inverter, the "Output power" status display is always shown as start image. From this status display you can go to all other menus.

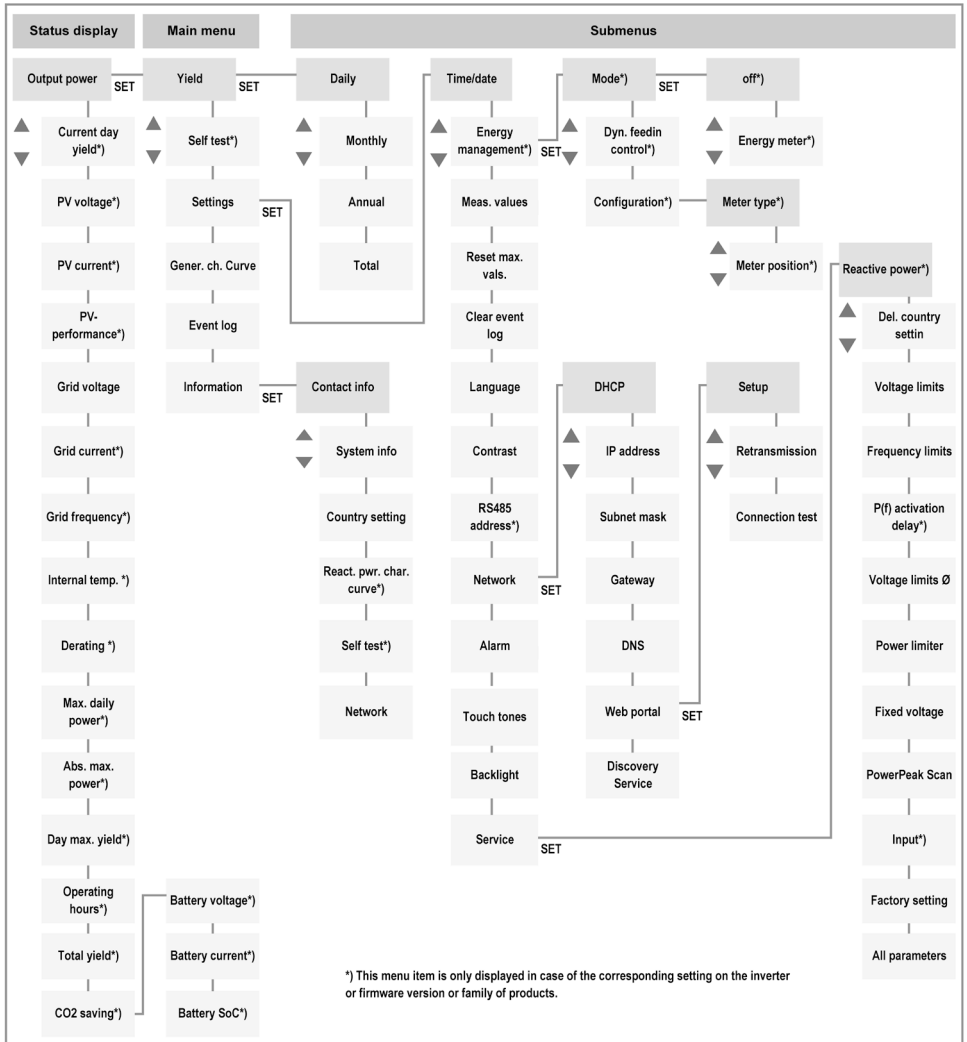

For reasons of clarity, only the " $\triangle\nabla$ " and " $\checkmark$ " operating buttons are depicted in the menu structure. The individual functions of the operating buttons are described in section 3.3.



Due to further technical development, changes of the menu structure are possible after delivery of this document. The current version of the menu structure is available in the download area of our homepage.

## 7.2 Navigating the menu structure

- To go from one "Output power" status display to the other status displays: scroll through the status displays with the " $\triangle\nabla$ " operating buttons.
- To go from the "Output power" status display to the main menu: press " $\checkmark$ ".
- To go to the other menu items within the main menu: scroll through the menu with the " $\triangle\nabla$ " operating buttons.
- To go from a menu item to a submenu: press " $\checkmark$ ".
- To go to other menu items within a submenu: scroll through the submenu with the " $\triangle\nabla$ " operating buttons.
- To return from any menu to the "Output power" status display: press and hold "X" for 1 second.

## 7.3 Status displays

The status displays show various measured values. "Output power" and "Grid voltage" have been preset in the factory and are always displayed. Further status displays that shall be shown can be defined in "Settings" > "Meas. values".

### 7.3.1 Displaying output power

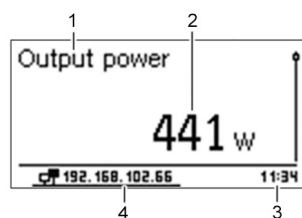

- 1 Menu name
- 2 Measurement with units
- 3 Time
- 4 IP address

In the event of too little solar radiation, the display does not show any measured value (e.g. at night).

All other menus of the status display are similar in structure and are therefore not mentioned separately.

## 7.4 Main menu

In the menu items of the main menu and the submenus, you can call various data and perform various settings. The most important menu items are described in the following section. The respective figures show examples.

### 7.4.1 Displaying yields

Structure of the "Yield" menus:

- On the left: definition of the period (daily/monthly/annual/total)
- On the right: individual yields per period

Monthly yield	
Jan 2018	49kWh
Dec 2017	54kWh
Nov 2017	66kWh

Via "✓" in the subsequent menu, the period of time displayed can be changed.

The periods contain the following number of individual yields:

- Daily yield: the last 31 days
- Monthly yield: the last 13 months
- Annual yield: the last 30 years

If the inverter had not been installed in one of the listed periods, the yield value "0" is displayed.

#### Yield (diagram representation)

By pressing "✓" in the menus with the daily, monthly and annual yields, you can go to the respective diagram view.

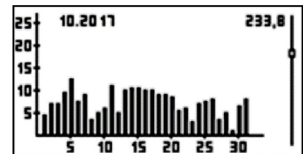

### 7.4.2 Generator characteristic curve

The "Gener. ch. Curve" menu displays the PV generator characteristic curve graphically.

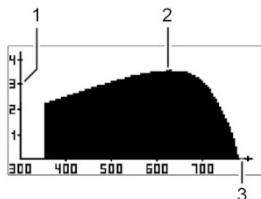

- 1 Y axis: power in kW
- 2 Vertex = MPP
- 3 X axis: input voltage in V



### 7.4.3 Event log

In the "Event log" menu, it is possible to call event messages sorted chronologically. By pressing "✓", the list of event messages can be displayed. The event messages possible are described in the section 9.4.

### 7.4.4 Information

The "Information" menu item contains the following submenu items:

- "Contact info": data for establishing contact with KOSTAL Solar Electric GmbH
- "System info" with:
  - Product name
  - Serial number of the inverter
  - Software and hardware versions of the inverter
  - Inverter address
  - Version of the inverter's operating instructions
- "Country setting": set country and country-specific grid parameters; set during initial commissioning
- "React.pwr.char. curve": diagram of the reactive power characteristic curve; only in certain countries
- "Network": network parameters, in part configurable in "Settings" > "Network"
  - Hostname
  - DHCP status: on/off
  - Link status: condition of the network connection
  - IP address of the inverter
  - Subnet mask
  - Gateway: IP address of the network gateway
  - DNS address: IP address of the DNS server
  - MAC: hardware address of the inverter
- "Results of last self-test" (only when Italy is set in the country setting)
- "Discovery Service": Yes = inverter is visible in the network for other participants of the network. No = inverter is not visible in the network for other participants of the network.

## 7.4.5 Self-test (only Italy)

During the self-test, the inverter tests its shutdown behaviour with regard to too high / too low grid voltage and frequency (7 test sections, approx. 40 minutes).

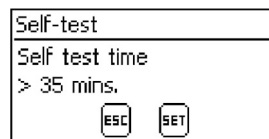

You will start the self-test by pressing "✓" longer. While the self-test is running, the measured values are shown on the display.

If the self-test has been successful, you can exit the menu by pressing "✓".

If a measured value lies outside of the required tolerance, the self-test aborts.

The "Self-test failed" message displayed has to be confirmed by pressing "✓". The, the self-test has to be repeated as soon as possible.

If not all the required conditions for performing the self-test have been met, an error message appears on the display:

Message	Cause	Remedy
MSD not ready	The self-test does not start because the inverter is not operational	Repeat the self-test later, when the inverter is feeding in
An error was detected	The self-test does not start because an internal error is present	If this error occurs repeatedly, inform the installer
Invalid grid conditions	Self-test abort due to invalid network conditions, e.g. in the event of an AC voltage that is too low	Repeat the self-test later
Not enough sunlight	Self-test does not start or aborts due to the fact that the solar radiation is too low, e.g. in the evening or at night	Repeat the self-test when there is sufficient solar radiation



If the self-test could not be run successfully, the inverter does no longer feed in.

- ▶ Repeat self-test as soon as possible.



The results of the self-test stored in the inverter can be shown on the display in "Information" > "Self-test".

## 7.4.6 Settings

From the "Settings" main menu you can go to the submenus with configurable parameters by pressing "✓".

Self-explanatory menus are not described in the following section.

### Energy management

The settings related to the energy management are described in "Feed-in management" (refer to section 4.8). The energy management includes the following submenus:

- "Mode": energy meter can be switched on or off
- "Dyn. feedin control": parameters for feed-in can be set.
- "Configuration": energy meters can be defined more precisely with the "Meter type" and "Meter position" submenus



This menu item is **not** displayed if "Battery" has been selected in the menu "Input".

### Measured values

In the "Meas. values" submenu, you determine which menus the status display shall contain.

The following measured values are available:

- "Output power": output power of the inverter<sup>1)</sup>
- "Current day yield": day yield since 00:00
- "PV voltage": voltage supplied by the PV generators
- "PV current": current supplied by the PV generators
- "PV performance": power generated by the PV generators
- "Grid voltage": voltage at the inverter connection<sup>1)</sup>
- "Grid frequency": frequency of the public grid
- "Internal temp": internal temperature of the inverter
- "Derating": reason for the power reduction

Possible reasons:

- Internal temperature too high
- User default for power limit
- Frequency too high
- Control by grid operator (feed-in management)
- Delayed power increase after start

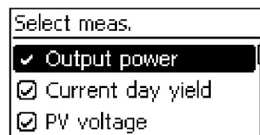

- "Max. daily power": maximum power of the current day<sup>2)</sup>
- "Abs. max. power": highest power fed in<sup>2)</sup>
- "Day max. yield": max. achieved day yield<sup>2)</sup>
- "Operating hours": operating hours on the grid (including hours at night)
- "Total yield ": yield since commissioning
- "CO<sub>2</sub> saving": CO<sub>2</sub> saving since commissioning
- Battery voltage: voltage delivered by the battery<sup>3)</sup>
- Battery current: charge/discharge current of the battery<sup>3)</sup>
- Battery SOC: charge state of the battery<sup>3)</sup>

<sup>1)</sup> Measured value is always displayed (it is not possible to switch it off)

<sup>2)</sup> Can be reset to zero via "Settings" > "Reset max. vals."

<sup>3)</sup> Is only displayed if "Battery" has been selected in the menu "Input".

## RS485 address

The address of the RS485 connection can be entered.

## Network

By pressing "✓", you can go to the following submenus: "DHCP", "IP address", "Subnet mask", "Gateway", "DNS", and "Web portal", which itself has submenus.



To set up the TCP/IP network connection, an input of parameters is required. Without knowing the parameter it is not possible to set up the TCP/IP network connection.

- ▶ If necessary, seek the advice of another specialist.

DHCP is activated in the inverter ex factory. Therefore, the IP address is automatically assigned to the network.

The parameters that are required for network communication (e.g. with a web portal) are configurable.

The following parameters can be opened and edited by pressing "✓":

- "DHCP"
- "IP address": IP address of the inverter
- "Subnet mask": information on the network and address space
- "Gateway": IP address of the network gateway
- "DNS address": IP address of the DNS server

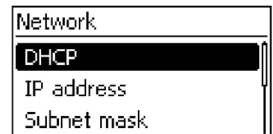

- "Web portal": parameters related to the web portal with the following submenus:
  - "Setup": selection of the web portal
  - "Retransmission": renewed transmission of existing data
  - "Connection test": test of the internet connection

## Alarm

Acoustic signals for event messages can be switched on or off (factory setting = switched off):

- 2 sounds: warnings
- 3 sounds: errors

## Backlight

The behaviour of the display lighting can be set:

- "Off": no backlight
- "Automatic": the backlight is switched on for 30 seconds after pressing a button
- "Feed-in mode": backlight depends on feed-in
  - "No feed-in": switched on for 30 seconds after pressing a button and, then, switched off
  - "Feed-in": switched on for 30 seconds after pressing a button and, then, dimmed

## 7.4.7 Service



Legally required parameters can be changed in the service menus. Any change may have a negative effect on the performance of the inverter and possibly even break a law.

- ▶ Only specialists that can ensure that the changes do not violate any applicable regulations and standards are allowed to perform any changes on the parameters of the service menus.

To go to the service submenus, the " $\Delta \nabla$ " operating buttons must be pressed simultaneously for 3 seconds.

Service
Enter key combination

Some dialogues of the service menus are password-protected. This password can be obtained from the support department of KOSTAL Solar Electric GmbH (refer to chapter 15).

Password
00000

## Setting the reactive power characteristic curve

Setting the reactive power characteristic curve is only required if this is specified for the selected country.

## Deleting the country setting

The selected country setting can be deleted. This task is password-protected (contact to KOSTAL Solar Electric GmbH is required). The inverter restarts and displays the guided initial commissioning again.

## Voltage limits

The voltage limits (peak values of the voltage) can be set by defining the following values:

- "Lower value"
- "Upper value"

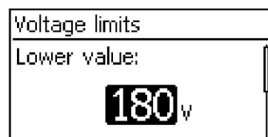

## Frequency limits

The frequency limits<sup>1)</sup> can be set by defining the following values:

- "Lower value"
- "Reactivation value"
- "Start value"
- "Upper value"

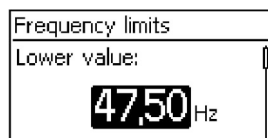

<sup>1)</sup> Switch-on threshold for power reduction (when frequency is too high)

## P(f) activation delay

The function of active power limitation for frequency transient has an activation delay which can be changed.

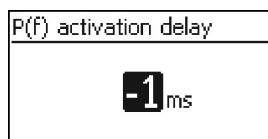

## Voltage limits $\emptyset$

Voltage limits  $\emptyset$  (mean values of the voltage) can be set by defining the following values:

- "Upper value"
- "Lower value"

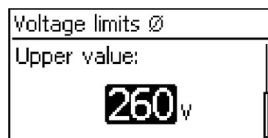

## Power limiter

The output power of the inverter can be limited up to a minimum of 500 W.

When the power is manually limited, the status display shows the "Power reduction" symbol and "Reason: user default".

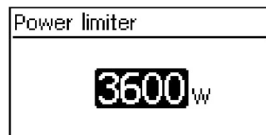

## Fixed voltage

Using the inverter for fixed voltage operation is not considered an intended use. If, nevertheless, the inverter shall be used for fixed voltage operation, consultation with KOSTAL Solar Electric GmbH is required.



### NOTE

The PV generator must be suitable for feeding in a fixed voltage.

Fixed input voltages in the inverter may damage unsuitable PV generators or reduce their yield.

- ▶ The parameter for fixed voltage are password-protected. The specialist can only change these parameters after consultation with KOSTAL Solar Electric GmbH.

The device can adjust the input voltage to a manually configurable value. Thereby, the automatic setting of the MPP (MPP tracking) is switched off.

The entered parameter value may lie between the maximum and minimum input voltage in 1 V increments.

A possible example for application of fixed voltage operation are hydropower plants.

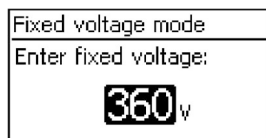

## PowerPeak Scan

With the PowerPeak scan, the energy yield of the inverter can be improved in the case of partial shadowing of PV strings (e.g. by parts of buildings, trees or power lines). The current MPP is intentionally left for a short time to hereby find the better MPP. The scan is only performed approx. every 10 minutes to impair the total energy yield caused by the brief power reduction during the scan process as little as possible.

The PowerPeak scan can be switched off in "Settings" > "Service" > "PowerPeak Scan".

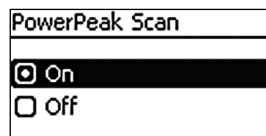
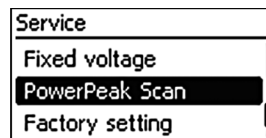

## Inputs

It is possible to select the functioning mode of the connected PV inputs: "PV", "Parallel", or "Battery".

"PV"

This setting is used when a PV generator is connected to the DC input.

"Parallel"

Both PV inputs (MPP tracker) operate synchronously. In this, the MPP tracking is determined by the first PV input.

This mode is applied when mounting two PV generator fields next to each other, e.g. when the input current exceeds the maximum permissible value in accordance with the type plate. The PV cables must be connected via a wye junction.

"Battery"

For inverters with one input, this input can be used as battery input (for inverters with 2 inputs, the second input). Subsequently, an exchange detection is performed interacting with the KOSTAL Smart Energy Meter. For this reason, the battery and the KSEM should have already been installed prior to the change. If the inverter is in error condition, restart device again on AC and DC side.

Application for use of the inverter as hybrid inverter or storage inverter and for connection of a battery and a KOSTAL Smart Energy Meter.

## Factory setting

Resetting the data to factory settings deletes the following data:

- Yield data
- Event messages
- Date and time
- Country setting
- Display language
- Network settings

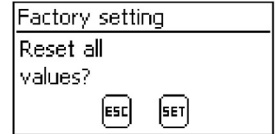

The inverter restarts. The initial commissioning must be performed again.

## All parameters

This menu item allows the change of further MSD parameters (only service technician).



## 8 Web portal



Automatic start of the transmission of unencrypted data.

After establishing the network connection, the inverter automatically starts data transmission to the server. If automatic transmission is not wanted:

▶ Remove network cable.

Or:

▶ Deactivate data transmission in "Settings" > "Network".

With the monitoring portal "KOSTAL (PIKO) Solar Portal", online monitoring of PV systems is easy and comfortable. Registration of the operator and the system in the "KOSTAL (PIKO) solar portal" is possible at: [www.kostal-solar-portal.com](http://www.kostal-solar-portal.com)

Operator guidance in the "KOSTAL (PIKO) solar portal" is easy and allows intuitive navigation. After registering and connecting the TCP/IP interface LAN to a PC, the portal displays data (e.g. yield data and performance of the connected PV generator).

The local network settings for the connection to the server have been set on the inverter. Setting the local network can be done automatically or manually:

- Automatic: if the DHCP prescribes the IP address in the network automatically, no settings are required on the inverter.
- Manual: if the IP address in the network is not assigned automatically, the IP address must be set manually on the inverter in "Settings" > "Network" (refer to section 7.4.4).

The URL of the web portal is saved permanently in the inverter and cannot be changed.

## 9 Fault elimination

Event messages indicate faults: the display will be flashing red and a text will describe the fault present.

### Typical display of an event message

Event messages contain the following information:

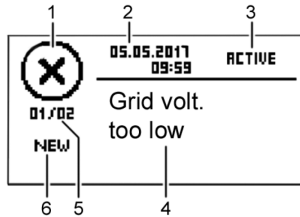

- 1 Event message type
- 2 Date/time of the event message
- 3 Note on the status of the event:  
*Active* = fault is still present  
*Date/time* = fault was eliminated at the indicated time
- 4 Cause of the fault
- 5 Consecutive number / total number in the list of events
- 6 Acknowledged / not acknowledged fault

Events are acknowledged by pressing the "X" or "△▽" operating buttons.

### 9.1 Event message type

#### Information

The inverter has detected an error which does not impair feed-in. There is no need for the user to intervene.

#### Warning

The inverter has detected an error which may cause reduced yields. It is recommended to eliminate the cause of error.

#### Error

The inverter has detected a serious error. The inverter does not feed in as long as the error is present.  
Inform the installer.

### 9.2 Alerting behaviour



By acknowledging the event message, the staff confirms that they have noticed the event message. The fault, however, persists. The cause of the fault is not eliminated thus.

New event messages appear immediately on the display. An event message disappears after the operator has acknowledged the event message or eliminated the cause of the fault.

If event messages, whose cause has been eliminated, have not yet been acknowledged, the status display will show an not opened message: .

## 9.3 Operation

In the main menu, select the "Event log" submenu.

- "✓": a list of the event messages appears.
- "△▽": scroll through the list.
- "NEW": select new event messages by pressing "✓" and acknowledge by pressing "X" or "△▽".









## 9.4 Event messages

The following table contains examples for event messages and their elimination.











Event message	Description	Type
<i>Battery charge over current (7559)</i>	Battery error due to a too high charging current. Battery charging is stopped. - Charging should be possible again after 5 min. If this error is permanently present, contact hotline.	⊗
<i>Battery discharge over current (7561)</i>	Battery error due to a too high discharging current. Battery discharging is stopped. - Discharging should be possible again after 5 min. If this error is permanently present, contact hotline.	⊗
<i>Battery input error detected</i>	Detecting the correct connection of the battery has failed. Possibly, the communication between battery and energy management has been interrupted, a condition which causes battery switch-off. - Check if the battery has been connected and set correctly. - In case everything has been connected and set correctly: perform restart of the inverter and the battery. First, start battery and then the inverter. Prior to switching on the DC power of the inverter, perform putting into operation in the KSEM.	⊗
<i>Battery over voltage (7551)</i>	Internal battery error due to overvoltage. Charging and discharging the battery is stopped. - This error is corrected by the normal household consumption. If this error is permanently present, contact hotline.	⊗

Event message	Description	Type
<i>Battery temperature high (7555)</i>	<p>Battery error due to temperature too high. Charging and discharging the battery is stopped.</p> <p>As soon as the battery is in the normal temperature range, the error is corrected.</p>	⊗
<i>Battery temperature low (7557)</i>	<p>Battery error due to temperature too low. Charging and discharging the battery is stopped.</p> <p>As soon as the battery is in the normal temperature range, the error is corrected.</p>	⊗
<i>Battery under voltage (7553)</i>	<p>Internal battery error due to undervoltage. Charging and discharging the battery is stopped.</p> <ul style="list-style-type: none"> <li>- If this error is permanently present, contact hotline.</li> </ul>	⊗
<i>Battery voltage error</i>	<p>The battery voltage detected by the inverter is outside the permitted operating voltage range of the battery. Possibly, the communication between battery and energy management has been interrupted, a condition which causes battery switch-off.</p> <ul style="list-style-type: none"> <li>- Check if the communication cable between battery and energy management has been installed correctly and if the battery has been set on the correct DC input.</li> <li>- In case everything has been connected and set correctly: perform restart of the inverter and the battery. First, start battery and then the inverter. Prior to switching on the DC power of the inverter, perform putting into operation in the KSEM.</li> </ul>	⊗
<i>Boost converter defect</i>	<p>The boost converter is defective; the inverter does not feed into the grid or feeds into the grid with reduced power.</p> <ul style="list-style-type: none"> <li>- Inform the installer.</li> </ul>	⊗
<i>Boost converter has wrong HW version</i>	<p>The inverter cannot detect an internal component, or the component does not match the other components. The inverter does not feed into the grid.</p> <ul style="list-style-type: none"> <li>- Inform the installer.</li> </ul>	⊗









Event message	Description	Type
<i>Boost converter malfunction</i>	An internal component of the inverter is defective. The inverter does not feed into the grid or feeds into the grid with reduced power. - Inform the installer.	⊗
<i>Boost converter not connected</i>	The connection of the internal components is disrupted. The inverter does not feed into the grid. - Inform the installer.	⊗
<i>Boost converter not recognised</i>	- Inform the installer.	⊗
<i>Country parameters invalid</i>	The inverter cannot feed into the grid because it does not have valid parameters. - Inform the installer.	⊗
<i>Data transfer failed</i>	A setting has failed, e.g. during initial commissioning, because it has not been transmitted correctly. - Perform the setting again. - If this error persists, inform the installer.	⊗
<i>Device overheated</i>	Despite power reduction, the maximum permissible temperature has been exceeded. The inverter does not feed into the grid until the permissible temperature range has been reached. - Check mounting conditions. - If the error occurs repeatedly, inform the installer.	⊗
<i>Failure - Battery Cell Imbalance (7564)</i>	Internal battery error - If this error is permanently present, contact hotline.	⊗
<i>Failure - Battery communication (7999)</i>	Battery communication error The RS485 connection between KOSTAL Smart Energy Meter and battery is disturbed. - Check RS485 connection. - Perform restart of the inverter and the battery. First, start battery and then connect the inverter. - If this error is permanently present, contact hotline.	⊗





Event message	Description	Type
<i>Failure - Battery DC Bus (7563)</i>	Battery short circuit error on the DC cables - Perform restart of the inverter and the battery. First, start battery and then connect the inverter.	
<i>Failure - Battery internal fault (7568)</i>	Internal battery error - Perform restart of the inverter and the battery. First, start battery and then connect the inverter. - If this error is permanently present, contact hotline.	
<i>Failure - Battery Precharge (7562)</i>	Battery Pre-charge error - Check selected number of modules in the battery. - If this error is permanently present, contact hotline.	
<i>Fan faulty</i>	The internal fan of the inverter is defective. The inverter does possibly feed into the grid with reduced power. - Inform the installer.	
<i>FE not connected</i>	Functional ground is not connected. The inverter must not feed into the grid for safety reasons. - Inform the installer.	
<i>Grid current DC offset too high</i>	The DC current share fed into the grid by the inverter exceeds the permissible value. The inverter is switched off automatically due to legal requirements as long as this error condition is present. - Inform the installer.	
<i>Grid frequency too high</i>	The grid frequency present at the inverter exceeds the permissible value. The inverter is switched off automatically due to legal requirements as long as this error condition is present. - If the error occurs repeatedly, inform the installer.	
<i>Grid frequency too high for reactivation</i>	The inverter cannot feed in again after switch-off because the grid frequency exceeds the legally required switch-on value. - If the error occurs repeatedly, inform the installer.	

Event message	Description	Type
<i>Grid frequency too low</i>	<p>The grid frequency present at the inverter falls below the permissible value. The inverter is switched off automatically as long as this error condition is present.</p> <ul style="list-style-type: none"> <li>- If the error occurs repeatedly, inform the installer.</li> </ul>	⊗
<i>Grid frequency too low for reactivation</i>	<p>The inverter cannot feed in again after switch-off because the grid frequency falls below the legally required switch-on value.</p> <ul style="list-style-type: none"> <li>- If the error occurs repeatedly, inform the installer.</li> </ul>	⊗
<i>Grid islanding detected</i>	<p>The grid does not carry voltage. The inverter must not feed into the grid for safety reasons. The inverter is switched off as long as this error condition is present. The display remains dark.</p> <ul style="list-style-type: none"> <li>- If the error occurs repeatedly, inform the installer.</li> </ul>	⊗
<i>Grid relay defective</i>	<p>The inverter has detected a defective grid relay and does not feed into the grid.</p> <ul style="list-style-type: none"> <li>- Inform the installer.</li> </ul>	⊗
<i>Grid voltage Ø too high</i>	<p>The output voltage averaged over a legally stipulated period exceeds the permissible tolerance range. The inverter is switched off automatically as long as this error condition is present.</p> <ul style="list-style-type: none"> <li>- If the error occurs repeatedly, inform the installer.</li> </ul>	⊗
<i>Grid voltage Ø too low</i>	<p>The output voltage averaged over a legally stipulated period falls below the permissible tolerance range. The inverter is switched off automatically as long as this error condition is present.</p> <ul style="list-style-type: none"> <li>- If the error occurs repeatedly, inform the installer.</li> </ul>	⊗
<i>Grid voltage too high</i>	<p>The grid voltage present at the inverter exceeds the permissible value. The inverter is switched off automatically due to legal requirements as long as this error condition is present.</p> <ul style="list-style-type: none"> <li>- If the error occurs repeatedly, inform the installer.</li> </ul>	⊗

Event message	Description	Type
<i>Grid voltage too high for reactivation</i>	<p>The inverter cannot feed in again after switch-off because the grid voltage exceeds the legally required switch-on value.</p> <ul style="list-style-type: none"> <li>- If the error occurs repeatedly, inform the installer.</li> </ul>	
<i>Grid voltage too low</i>	<p>The grid voltage present at the inverter falls below the permissible value. The inverter is switched off automatically due to legal requirements as long as this error condition is present.</p> <ul style="list-style-type: none"> <li>- If the error occurs repeatedly, inform the installer.</li> </ul>	
<i>Grid voltage too low for reactivation</i>	<p>The inverter cannot feed in again after switch-off because the grid voltage falls below the legally required switch-on value.</p> <ul style="list-style-type: none"> <li>- If the error occurs repeatedly, inform the installer.</li> </ul>	
<i>Intern. error</i>	<ul style="list-style-type: none"> <li>- If the error occurs repeatedly, inform the installer.</li> </ul>	
<i>Intern. info.</i>	<ul style="list-style-type: none"> <li>- If the error occurs repeatedly, inform the installer.</li> </ul>	
<i>Intern. warning</i>	<ul style="list-style-type: none"> <li>- If the error occurs repeatedly, inform the installer.</li> </ul>	
<i>Isolation error</i>	<p>The insulation resistance between positive or negative input and ground falls below the permissible value. The inverter does not feed into the grid.</p> <ul style="list-style-type: none"> <li>- Inform the installer.</li> </ul>	
<i>L and N swapped</i>	<p>Outer and neutral conductors are connected the wrong way. The inverter must not feed into the grid for safety reasons.</p> <ul style="list-style-type: none"> <li>- Inform the installer.</li> </ul>	
<i>No branding</i>	<p>The inverter has wrong or inaccurate device data. The inverter does not feed into the grid.</p> <ul style="list-style-type: none"> <li>- Inform the installer.</li> </ul>	
<i>No connection to the energy meter</i>	<p>There is no communication connection or an incorrect communication connection between inverter and energy meter.</p> <ul style="list-style-type: none"> <li>- Have the installer check the connection.</li> </ul>	



Event message	Description	Type
<i>Overheating HSS</i>	<p>The maximum temperature of the boost converter has been exceeded. The inverter does not feed into the grid until the permissible temperature range has been reached.</p> <ul style="list-style-type: none"> <li>- Check mounting conditions.</li> <li>- If the error occurs repeatedly, inform the installer.</li> </ul>	
<i>Power reduction due to temperature</i>	<p>The inverter reduces its output power because the maximum temperature has been reached.</p> <ul style="list-style-type: none"> <li>- Check mounting conditions.</li> <li>- If the error occurs repeatedly, inform the installer.</li> </ul>	
<i>PV current too high</i>	<p>The input current at the inverter exceeds the permissible value. The inverter limits the current to the permissible value.</p> <ul style="list-style-type: none"> <li>- If the error occurs repeatedly, inform the installer.</li> </ul>	
<i>PV voltage too high</i>	<p>The input voltage present at the inverter exceeds the permissible value.</p> <ul style="list-style-type: none"> <li>- Switch off the DC disconnect of inverter and inform the installer.</li> </ul>	
<i>Reading CountryCode failed</i>	<p>Inconsistency between the selected country setting and the one stored in the memory.</p> <ul style="list-style-type: none"> <li>- Inform the installer.</li> </ul>	
<i>Reading CountryCode failed</i>	<p>The inverter has not been able to read out the set country correctly.</p> <ul style="list-style-type: none"> <li>- Inform the installer.</li> </ul>	
<i>Residual current too high</i>	<p>The residual current flowing from the positive or negative input through the PV generators to ground exceeds the legally permissible value. The inverter is switched off automatically as long as this error condition is present.</p> <ul style="list-style-type: none"> <li>- Inform the installer.</li> </ul>	
<i>RS485-Gateway activated</i>	<p>It is not possible to communicate with the inverter via the RS485 interface.</p> <ul style="list-style-type: none"> <li>- Disconnect inverter from the grid and restart (AC reset).</li> <li>- Inform the installer.</li> </ul>	

Event message	Description	Type
<i>Self test failed</i>	An error has occurred during self-test; the self-test has been aborted. <ul style="list-style-type: none"> <li>- If the self-test is repeatedly aborted at different times of the day although the grid voltage and frequency lie within the limit values of the country setting, inform the installer.</li> </ul>	
<i>Software incompatible</i>	After a firmware update the various software versions in the inverter do no longer match. <ul style="list-style-type: none"> <li>- Perform the firmware update again with a valid update file.</li> <li>- If the error occurs repeatedly, inform the installer.</li> </ul>	
<i>System on lockdown</i>	This error is always generated together with the error "Battery input error detected". <ul style="list-style-type: none"> <li>- Proceed as described in "Battery input error detected".</li> </ul>	
<i>Time/date lost</i>	The inverter has lost the time because it has been disconnected from the grid for too long. Storage of yield data is only possible with the wrong date. <ul style="list-style-type: none"> <li>- Correct the time in "Settings" &gt; "Time/date".</li> </ul>	

## 10 Maintenance and care

### 10.1 Maintenance

The inverter does not require any maintenance.

### 10.2 Care

The care of the inverter is limited to the following measures:

- Removing dust
- Cleaning

## 10.2.1 Removing dust

Remove dust from the cooling fins in the front and rear of the device by using compressed air of a maximum of 2 bar.

## 10.2.2 Cleaning



### **DANGER**

Voltage.

There is a risk of death by electrocution.

- ▶ Only clean device with a slightly moist cloth.

### **Light soiling:**

Clean surface of the inverter with a slightly moist cloth (use clear water).

### **Heavy soiling:**

1. Clean surface of the inverter with a slightly moist cloth. In addition, use a cleaning agent without solvents or disinfectants, that does not contain any granular or sharp-edged substances.
2. Remove any residues of the cleaning agent.

## 11 Disposal



- ▶ Do not dispose of the inverter with household waste.
- ▶ Return the inverter to KOSTAL Solar Electric GmbH customer service with the note: "For disposal".
- ▶ The device packaging consists of recyclable materials.

## 12 Technical data

The values in the technical data have been determined at a temperature of 25 °C (77 °F).

### 12.1 PIKO MP plus 1.5-1, 2.0-1, 2.5-1, 3.0-1 and 3.6-1

	PIKO MP plus 1.5-1	PIKO MP plus 2.0-1	PIKO MP plus 2.5-1	PIKO MP plus 3.0-1	PIKO MP plus 3.6-1
Installation altitude	Max. 2000 m above sea level				
<b>DC input side (PV generator connection)</b>					
Max. input voltage	450 V			750 V	
MPP voltage range	75 V to 360 V			125 V to 600 V	150 V to 600 V
Operating voltage range at nominal power	120 V to 360 V	160 V to 360 V	200 V to 360 V	230 V to 600 V	280 V to 600 V
Number of MPP trackers	1				
Max. input current	13 A				
Max. input power with max. output active power	1540 W	2050 W	2560 W	3070 W	3770 W
Max. short-circuit current	15 A				
Maximum energetic recovery current of the inverter to the solar module	0 A				
<b>AC output side (grid connection)</b>					
Output voltage	185 V to 276 V				
Nominal output voltage	230 V				
Max. output current	12 A	12 A	14 A	14 A	16 A
Max. active power (cosPhi = 1)	1500 W	2000 W	2500 W	3000 W	3680 W
Maximum apparent power	1500 VA	2000 VA	2500 VA	3000 VA	3680 VA
Nominal power	1500 W	2000 W	2500 W	3000 W	3680 W
Nominal frequency	50 Hz and 60 Hz				
Grid frequency	45 Hz to 65 Hz				

	PIKO MP plus 1.5-1	PIKO MP plus 2.0-1	PIKO MP plus 2.5-1	PIKO MP plus 3.0-1	PIKO MP plus 3.6-1
Power loss during nighttime operation	< 3 W				
Feed-in phases	One-phase				
Distortion factor (cosPhi = 1)	< 3 %				
Power factor cosPhi	0.8 capacitive to 0.8 inductive				
Highest output fault current	0.0 A				
Highest overcurrent protection	28 A			40 A	
<b>Characterisation of the operating behaviour</b>					
Max. efficiency	97.40 %	97.40 %	97.40 %	97.00 %	97.00 %
European efficiency	96.10 %	96.50 %	96.60 %	96.30 %	96.30 %
MPP efficiency	> 99.7 % (static), > 99 % (dynamic)				
Internal consumption	< 20 W				
Power derating (power reduction) at full power from	50 °C (T <sub>amb</sub> )				45 °C (T <sub>amb</sub> )
<b>Safety</b>					
Isolation principle	No galvanic isolation, without transformer				
Grid monitoring	Yes, integrated				
Residual current monitoring	Yes, integrated (the inverter cannot cause a DC residual current due to the design)				
Protection class	Protection class 2 (RCD type A sufficient)				
<b>Operating conditions</b>					
Area of application	Indoors, outdoors (degree of soiling 3)				
Climate category i.a.w. IEC 60721-3-4	4K4H				
Ambient temperature	-25 °C to +60 °C				
Storage temperature	-30 °C to +80 °C				
Relative humidity	0 % to 100 %, non-condensing				
Noise emission (typical)	31 dB(A)				

	PIKO MP plus 1.5-1	PIKO MP plus 2.0-1	PIKO MP plus 2.5-1	PIKO MP plus 3.0-1	PIKO MP plus 3.6-1
<b>Equipment and design</b>					
Degree of protection	IP 65				
Overvoltage category	III (AC), II (DC)				
DC connection	Phoenix Contact SUNCLIX (1 pair), mating plugs included in the scope of delivery				
AC connection	Wieland RST25i3 plug, mating plug included in the scope of delivery				
Dimensions	399 x 657 x 222 mm				
Weight	11.7 kg			12.4 kg	
Communication interfaces	RS-485 (1 x RJ45 socket), Ethernet-interface (1 x RJ45), Modbus RTU (1 x RJ45 socket: connection to energy meter)				
Integrated DC disconnecter	Yes, conform to DIN VDE 0100-712				
Cooling principle	Temperature controlled fan, variable-speed, internal (dust-protected)				
Test certificate	Refer to certificates download at the product page of homepage				

## 12.2 PIKO MP plus 3.0-2, 3.6-2, 4.6-2 and 5.0-2 \*

	PIKO MP plus 3.0-2	PIKO MP plus 3.6-2	PIKO MP plus 4.6-2	PIKO MP plus 5.0-2
Installation altitude	Max. 2000 m above sea level			
<b>DC input side (PV generator connection)</b>				
Max. input voltage	750 V			
MPP voltage range	125 V to 600 V	150 V to 600 V	150 V to 600 V	150 V to 600 V
Operating voltage range at nominal power	230 V to 600 V	280 V to 600 V	360 V to 600 V	360 V to 600 V
Number of MPP trackers	2			
Max. input current	2 x 13 A			
Max. input power with max. output active power	3070 W	3770 W	4740 W	5200 W

\* Available as of Q2/2020

	PIKO MP plus 3.0-2	PIKO MP plus 3.6-2	PIKO MP plus 4.6-2	PIKO MP plus 5.0-2
Max. short-circuit current	15 A			
Maximum energetic recovery current of the inverter to the solar module	0 A			
<b>AC output side (grid connection)</b>				
Output voltage	185 V to 276 V			
Nominal output voltage	230 V			
Max. output current	14 A	16 A	20 A	22 A
Max. active power (cosPhi = 1)	3000 W	3680 W	4600 W	5000 W
Maximum apparent power	3000 VA	3680 VA	4600 VA	5000 VA
Nominal power	3000 W	3680 W	4600 W	5000 W
Nominal frequency	50 Hz and 60 Hz			
Grid frequency	45 Hz to 65 Hz			
Power loss during nighttime operation	< 3 W			
Feed-in phases	One-phase			
Distortion factor (cosPhi = 1)	< 3 %			
Power factor cosPhi	0.8 capacitive to 0.8 inductive			
Highest output fault current	0.0 A			
Highest overcurrent protection at the output	40 A	40 A	57 A	57 A
<b>Characterisation of the operating behaviour</b>				
Max. efficiency	97.00 %	97.00 %	97.40 %	97.40 %
European efficiency	96.30 %	96.30 %	96.90 %	96.80 %
MPP efficiency	> 99.7 % (static), > 99 % (dynamic)			
Internal consumption	< 20 W			
Power derating at full power from	45 °C (T <sub>amb</sub> )	45 °C (T <sub>amb</sub> )	40 °C (T <sub>amb</sub> )	40 °C (T <sub>amb</sub> )
<b>Safety</b>				
Isolation principle	No galvanic isolation, without transformer			
Grid monitoring	Yes, integrated			
Residual current monitoring	Yes, integrated (the inverter cannot cause a DC residual current due to the design)			
Protection class	Protection class 2 (RCD type A sufficient)			

	PIKO MP plus 3.0-2	PIKO MP plus 3.6-2	PIKO MP plus 4.6-2	PIKO MP plus 5.0-2
<b>Operating conditions</b>				
Area of application	Indoors, outdoors (degree of soiling 3)			
Climate category i.a.w. IEC 60721-3-4	4K4H			
Ambient temperature	-25 °C to +60 °C			
Storage temperature	-30 °C to +80 °C			
Relative humidity	0 % to 100 %, non-condensing			
Noise emission (typical)	31 dB(A)			
<b>Equipment and design</b>				
Degree of protection	IP 65			
Overvoltage category	III (AC), II (DC)			
DC connection	Phoenix Contact SUNCLIX (2 pair), mating plugs included in the scope of delivery			
AC connection	Wieland RST25i3 plug, mating plug included in the scope of delivery			
Dimensions	399 x 657 x 222 mm			
Weight	13 kg	13 kg	13.1 kg	13.1 kg
Communication interfaces	RS-485 (1 x RJ45 socket), Ethernet-interface (1 x RJ45), Modbus RTU (1 x RJ45 socket: connection to energy meter)			
Integrated DC disconnecter	Yes, conform to DIN VDE 0100-712			
Cooling principle	Temperature controlled fan, variable-speed, internal (dust-protected)			
Test certificate	Refer to certificates download at the product page of homepage			



## 13 Table of countries

The country of use is set by the installer during the installation of the device. The country-specific grid parameters will vary depending on the set country of use.

Due to legal requirements, the country-specific values may change at short notice. Any information on the current grid parameters of the countries of use are available in the download area of the KOSTAL Solar Electric GmbH homepage.

## 14 Liability, warranty

The conditions for the device are available for downloading on the KOSTAL Solar Electric GmbH homepage: [www.kostal-solar-electric.com/download](http://www.kostal-solar-electric.com/download) > Type of device.

## 15 Contact

In the event of complaints or faults, please contact your local dealer, where you purchased the product. He will assist you in all respects.

Country	Phone	Email
Germany	+49 (0)761 477 44 - 222	service-solar@kostal.com
Switzerland	+41 32 5800 225	service-solar@kostal.com
France, Belgium, Luxembourg	+33 16138 4117	service-solar-fr@kostal.com
Greece	+30 2310 477 555	service-solar-el@kostal.com
Italy	+39 011 97 82 420	service-solar-it@kostal.com
Spain, Portugal	+34 961 824 927	service-solar-es@kostal.com
Turkey	+90 212 803 06 26	service-solar-tr@kostal.com
China	+86 21 5957 0077-7999	service-solar-cn@kostal.com

## 16 Annex

### 16.1 Drilling pattern for wall mounting

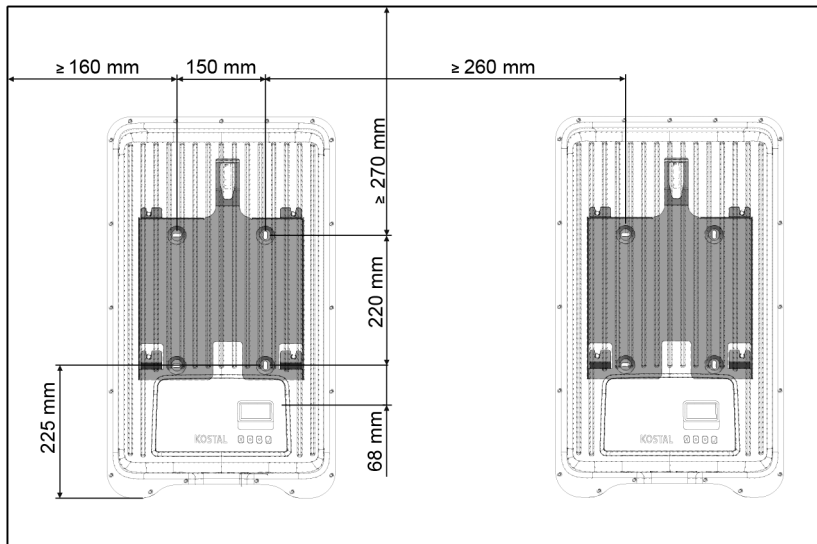



# KOSTAL

KOSTAL Solar Electric GmbH  
Hanferstr. 6  
79108 Freiburg i. Br.  
Deutschland  
Telefon: +49 761 47744 - 100  
Fax: +49 761 47744 - 111

KOSTAL Solar Electric Ibérica S.L.  
Edificio abm  
Ronda Narciso Monturiol y Estarriol, 3  
Torre B, despachos 2 y 3  
Parque Tecnológico de Valencia  
46980 Valencia  
España  
Teléfono: +34 961 824 - 934  
Fax: +34 961 824 - 931

KOSTAL Solar Electric France SARL  
11, rue Jacques Cartier  
78280 Guyancourt  
France  
Téléphone: +33 1 61 38 - 4117  
Fax: +33 1 61 38 - 3940

KOSTAL Solar Electric Hellas E.Π.Ε.  
47 Steliou Kazantzidi st., P.O. Box: 60080  
1st building – 2nd entrance  
55535, Pilea, Thessaloniki  
Ελλάδα  
Τηλέφωνο: +30 2310 477 - 550  
Φαξ: +30 2310 477 - 551

KOSTAL Solar Electric Italia Srl  
Via Genova, 57  
10098 Rivoli (TO)  
Italia  
Telefono: +39 011 97 82 - 420  
Fax: +39 011 97 82 - 432

KOSTAL Solar Electric Turkey  
Mahmutbey Mah. Taşocağı Yolu  
No:3 (B Blok), Ağaoğlu My Office212,  
Kat:16, Ofis No: 269  
Bağcılar - İstanbul  
Türkiye  
Telefon: +90 212 803 06 24  
Faks: +90 212 803 06 25

KOSTAL (Shanghai) Management Co., Ltd  
Yuan Gao Road 77, Anting, Jiading,  
201814 Shanghai, China  
Tel: +86 21 5957 0077-7189  
Fax: +86 21 5957 8294

[www.kostal-solar-electric.com](http://www.kostal-solar-electric.com)