

■ MANUAL



D-A-CH VARIANTS

For product-specific data, please refer to the corresponding product data sheet!

TABLE OF CONTENTS

1.	NOTES ON DEVICE DOCUMENTATION	5
1.1	Scope of validity	5
1.2	Target groups	5
1.3	Retention of documents	5
1.4	Symbols used	6
2.	SAFETY	6
2.1	Intended use	6
2.2	Safety instructions	6
2.3	Characteristic values of the rating plate	8
2.4	Symbols on the device	9
3.	DESCRIPTION OF THE TWO D-A-CH VARIANTS	9
3.1	Identification	9
3.2	System releases	9
3.3	Country releases	9
3.4	Net shapes	10
3.5	Functions of the mains switch box	10
3.5.1	Mode of operation of the mains switch box (observe wiring diagram!)	11
4.	TRANSPORTATION AND STORAGE	12
4.1	Delivery condition	12
4.2	Storage	13
5.	INSTALLATION	13
5.1	Scope of delivery	13
5.2	Mounting the mains switch box	14
5.2.1	Mounting location	14
5.2.2	Mounting position	14
5.2.3	Minimum distances	14
5.3	Connecting the mains switch box	15
5.3.1	Cable entry and connections	15
5.3.2	Connections to the terminal strips	16
5.3.3	Configuration of the mains disconnection operating mode	17
5.3.4	Installation of a KOSTAL Energy Meter	20
5.3.5	Installation of miniature circuit breakers and residual current circuit breakers for PLENTICORE G3	20
5.3.6	Connecting power and control cables	22
5.3.7	Connecting the data cable	23
5.3.8	Connecting the protective conductor	23

■ MANUAL

6.	CIRCUIT DIAGRAMS OF THE TWO VARIANTS	24
6.1	Wiring environment	26
7.	COMMISSIONING	27
7.1	Maximum currents and ambient temperature	27
7.2	Prerequisite for commissioning	27
7.3	Commissioning procedure	27
7.4	Activation of the backup power mode	28
8.	ERROR RESOLUTION	29
9.	DE-ENERGIZE MAINS SWITCH BOX	29
10.	MAINTENANCE AND CLEANING	29
11.	DISPOSAL	29
12.	TECHNICAL DATA	30
13.	EC DECLARATIONS OF CONFORMITY	36

1. NOTES ON THE DEVICE DOCUMENTATION

1.1 Scope of validity

This manual is valid for the D-A-CH (Germany - Austria - Switzerland) versions of the mains switching boxes for the KOSTAL PLENTICORE G3 system. The mains switch boxes may only be used in this system. If you have any questions about the system, please contact your KOSTAL partner.

1.2 Target groups

This device documentation is intended for operators and installers of the KOSTAL PLENTICORE hybrid inverter system "G3" in conjunction with the mains switching box or mains switching device from enwitec electronic GmbH.



Note

Installation, connection and maintenance work may only be carried out by trained electricians (e.g. electricians, electrical system fitters, electromechanics, industrial electricians).

1.3 Storage of the documents

The operator of the system must ensure that this device documentation is accessible to the responsible persons at all times if required. If the original document is lost, you can download a current version of this device documentation from our website (www.enwitec.eu/downloads).

MANUAL

1.4 Used Symbols

The following safety instructions and general notes are used in this device documentation.

DANGER

"Danger" indicates a safety instruction which, if ignored, will lead directly to death or serious injury!

WARNING

"Warning" indicates a safety instruction which, if ignored, could result in death or serious injury!

CAUTION

"Caution" indicates a safety instruction which, if ignored, may result in minor or moderate injury!

ATTENTION

"Attention" indicates a safety instruction which, if ignored, may result in material damage.



"Info" indicates important information and notes that are not relevant to safety.

2. SAFETY

2.1 Intended use Use

All instructions for use in this product documentation and in the product documentation for the PLENTICORE G3 hybrid inverter must be observed. The mains changeover box may only be used in conjunction with the KOSTAL PLENTICORE G3 system.

2.2 Safety instructions

The following safety instructions apply when handling the mains switch box:

DANGER

Danger to life due to high voltages!

Components in the mains switch box are under dangerously high voltage during operation.

Installation, connection and maintenance work may only be carried out by trained electricians (e.g. electricians, electrical system fitters, electromechanics, industrial electricians).

DANGER

Danger to life due to high voltages!

When working on the domestic power supply, dangerously high voltages may be present when the PLENTICORE G3 is switched on. De-energize the PLENTICORE G3 completely before starting work on the domestic power supply.



Note

The configuration of the mains disconnection (all-pole or only three-pole with continuous neutral conductor) is initially carried out during commissioning using jumpers on the terminal strips. The jumpers are included in the scope of delivery!



Note

The grid switch box is designed so that the installed circuit breakers and residual current circuit breakers can be operated by laypersons. KOSTAL Smart Energy Meters can be integrated as an option (a list of meters compatible with the PLENTICORE G3 can be found in the KOSTAL Solar Electric download area at www.kostal-solar-electric.com/download), as well as miniature circuit breakers (and additional residual current circuit breakers if required) if the PLENTICORE G3 is connected to the grid switch box.

DANGER

Danger to life due to improper use!

No use for life-sustaining medical devices and systems.

In general, the backup power system described here must NOT be used to supply life-sustaining medical devices and systems. The backup power system does NOT guarantee an uninterruptible power supply!

DANGER

Danger to life due to explosion!

Mechanical damage can lead to heating or short circuits. This could lead to fire or explosion of the appliance.

The mains switch box may only be stored and operated in non-hazardous areas. The system components must be protected against mechanical damage.

WARNING

Fire hazard due to short circuit!

In the event of a short circuit, sparkovers or electric arcs may occur.

WARNING

Fire hazard due to mechanical damage!

Mechanical damage to the mains switch box can lead to heating or short circuits. This could lead to fire or explosion of the appliance. The mains switch box must be protected against mechanical damage, e.g. unauthorized opening.

MANUAL





2.3 Characteristic values of the rating plate

In addition to the identification data, the type plate contains the following technical data that must be observed during operation. The type plate is located on the inside and on the top right outside of the mains switch box.

- **Mains form Mains connection**
The supplying network can be a TN-C network, a TN-S network or a TT network!
- **Mains form Consumer system**
In the case of a supplying TN-C system, the neutral conductor and protective conductor must be separated in the house installation BEFORE connection.
to the mains switch box (terminal strip X1). We then recommend configuring a three-pole disconnection (the mains neutral conductor is continuous). In principle, all-pole disconnection can also be selected.
In the case of a supplying TN-S network (network connection point is already provided by the network operator with a separate neutral conductor and protective earth conductor), we recommend disconnecting all poles from the network (the earthing device within the mains switch box is then active).
All-pole disconnection must be configured for a supplying TT network.
- **Rated current I_{ng}**
This operating current via terminal strip X3 (= backup consumer) is limited to 30 A at an ambient temperature of maximum 40°C. If ventilation valves are used (see technical data), the current can be increased to a maximum of 43.5 A, but with a simultaneous reduction of the maximum ambient temperature to 25°C (the protection rating is then also reduced to IP44!).
- **Total rated current I_{nA}**
The total rated current via the NON-backup-supported terminal strip X2 and the "backup" terminal strip X3 must not exceed short-time summation current of 63 A must not be exceeded. The thermal summation current, in turn, should not exceed a factor of must not exceed approx. 0.8 - in relation to the fuse value used at the grid connection point or meter pre-fuse (for fuse 63 A gG * 0.8 = approx. 50 A!).
- **Maximum back-up fuse Mains**
You may use a maximum back-up fuse of 63 A (characteristic gG).
- **Ambient temperature**
Without additional ventilation valves, you may use the mains switch box in a temperature range of -25°C...+40°C. The Load factor "RDF1" means that this can be a continuous, thermal rated current of 30 A per phase. The maximum ambient temperature may be 40°C.
With additional ventilation valves, you can use the mains switch box in a temperature range of -25°C+25°C. The current can be increased to up to 43.5 A per phase. The use of ventilation valves reduces the degree of protection from IP65 to IP44.
Indoor installation is mandatory for both operating modes (see technical data).
- **IEC/EN - Standard specification**
The mains switchbox meets the requirements of IEC/EN "Low-voltage switchgear and controlgear assemblies"
EN 61439-1 / EN 61439-2 / EN 61439-3

2.4 Symbols on the device

The following symbols are located on the mains switch box:

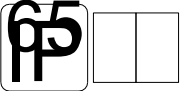
Icon	Description
	The electrical appliance must not be disposed of with household waste.
	CE mark (Confirms conformity with EU directives)
	Protection class II The mains switch box has reinforced insulation to the internal live parts and is therefore protected against direct and indirect contact.
	IP= Ingress Protection Meaning of number 6 (left): dust-tight Meaning of number 5 (right): Protection against water jets (nozzle) from any angle
	P= Ingress Protection Meaning of number 4 (left): protected against solid foreign bodies with a diameter ≥ 1.0 mm Meaning of number 4 (right): Protection against splashing water from all sides

44

3. DESCRIPTION OF THE TWO D-A-CH- VARIANTS

3.1 Identification

The two variants can be identified by the information on the type plate. The type plate is located on the inside and at the top on the right outside of the mains switch box.

3.2 System releases

The two variants of the mains switchover boxes

- Variant 10017468 (for Germany and Switzerland)
- Variant 10017469 (for Austria)

may only be operated in the configuration with the PLENTICORE hybrid inverter G3 4.0-20 kW.

3.3 Country releases

The two variants are basically the same, but in contrast to the 10017468 (DE-CH) variant, the Austrian variant 10017469 has a buffering of the coils of the mains isolating contactor and earthing contactor and thus enables FRT (Fault Ride Through) support of the grid by the inverter(s). This is realized by means of a 24 VDC buffer power supply unit and corresponding contactor coils. In principle, the Austrian version can of course also be used in Germany and Switzerland, but is more expensive due to the design effort involved.

The type of supply network of the network operator (network type) must be taken into account and, based on this, it must be determined whether a three-pole or all-pole disconnecting configuration of the mains switchover box should be implemented. All-pole disconnection is always required for a supplying TT network. A detailed description of the network types can be found in section 3.4.

MANUAL

3.4 Net shapes

10017468 (Germany/Switzerland)

Grid connection point	Net shape		All-pole disconnection permitted	Three-pole separation permitted
	Consumer system in mains operation			
TN-C	TN-S*		✓	✓ (recommended)
TN-C	TN-C		✗ prohibited	✗ prohibited
TN-S	TN-S		✓	✗ prohibited
TT	TT		✓	✗ prohibited

* Splitting/disconnection must take place BEFORE the mains switchover box, starting from the mains side (neutral conductor and protective conductor must already be separated before terminal strip X1).

10017469 (Austria)

Grid connection point	Net shape		All-pole disconnection permitted	Three-pole separation permitted
	Consumer system in mains operation			
TN-C	TN-S*		✓	✓ (recommended)
TN-C	TN-C		✗ prohibited	✗ prohibited
TT	TT		✓**	✗ prohibited

* Splitting/disconnection must take place BEFORE the mains switchover box, starting from the mains side (neutral conductor and protective conductor must already be separated before terminal strip X1).
Three-pole disconnection is always desirable, but the cable length from the neutral connection to the mains switch box must not exceed 2 m! If the cable length exceeds 2 m, all-pole disconnection is required (from OVE E 8101, Part 5.55; reference in TA EV 2020/II/112 - "6.11.4 Changeover device")

** According to OVE E 8101:2019: Protective measure by suitable earthing of the decentralized generation system is accepted. The suitability or acceptance of the grid switch box must be clarified with the grid operator!

3.5 Functions of the mains switchbox

- Measurement and transmission of the parameters required for energy management if a KOSTAL Smart Energy Meter is installed (a list of meters compatible with the PLENTICORE G3 can be found in the KOSTAL Solar Electric download area at www.kostal-solar-electric.com/download) Grid disconnection in the event of a grid failure/grid fault.
- Reconnection on mains recovery/mains fault rectification.
- Establishment of the safety-relevant earth connection in backup power mode with all-pole disconnection.
- If required: Separation of the consumer circuits into "normal" consumer loads (without backup power functionality = terminal strip X2) and backup loads (with backup support = terminal strip X3).
- Connection of the PLENTICORE G3 Hybrid inverter directly to the mains switch box. Various constellations of miniature circuit breakers and residual current circuit breakers can be integrated into the mains switch box on site for this purpose.

Separation of the consumer circuits

Separation into "normal" consumer loads and backup loads is not necessary, but is possible as an option. If all loads are to be supplied via backup power (via terminal strip X3), it must be ensured that the total load of the loads in backup power mode is not higher than the rated power of the PLENTICORE G3.

In addition, the maximum total currents in mains parallel operation must not be exceeded. The values of the maximum total currents in mains parallel operation are defined as follows:

Rated current I_{ng} via mains isolating contactor Q1 and terminal strip X3

While maintaining protection class IP65 (no ventilation valves), the rated thermal current should not exceed 30 A per phase (= approx. 20 kW).

If higher continuous currents are required, ventilation valves can be retrofitted, which allow a higher continuous current of approx. 43.5 A per phase (= approx. 30 kW). The ambient temperature should be limited to approx. 25°C for these high currents (e.g. installation in a cellar or similar).



Excessive currents cause an increased temperature inside the mains switch box and the components age correspondingly faster, or false tripping of the installed circuit breakers or residual current circuit breakers can also occur.

Operating current I_b via terminal strip X2

Terminal strip X2 is used for connecting loads that are NOT backup-supported, such as heat pumps or e-chargers. As the thermal current only has to be conducted via the internal wiring (16 mm² stranded copper wire) and the power terminals - no contactor contacts - very high currents are possible here, theoretically up to the rated current of the maximum permissible back-up fuse of 63 A gG for a short time. The thermal continuous operating current via X2 is approx. 50 A per phase (= approx. 35 kW).

Rated current of the mains switchover box "total" I_{nA}

The total rated current I_{nA} of the mains switchover box is always the sum of the two currents already defined $\Sigma I_{ng} + I_{nA}$. The total current should always be lower than the maximum permissible back-up fuse of the mains switchover box: 63 A gG!

3.5.1 Mode of operation of the mains switch box (observe

wiring diagram!) Mains present and OK

The KOSTAL Energy Meter (KSEM/KEM-C/KEM-P) installed in the system diagnoses the grid voltage as "OK". Accordingly, the PLENTICORE G3 hybrid inverter does NOT activate the grid interlock relay "K1".

When the circuit breaker F1 is switched on, the control circuit is activated and, depending on the initial configuration of the mains disconnection, only Q1 (mains disconnection contactor) or Q1 and Q2 (earthing contactor) is/are energized.



Battery storage is essential for backup operation. Backup mode cannot be set up in the PLENTICORE G3 without an installed battery storage system.

A list of battery storage systems compatible with the PLENTICORE G3 can be found in the KOSTAL Solar Electric download area at www.kostal-solar-electric.com/download.

MANUAL

Power failure/mains error

In the event of a direct failure of phase L1 (the control circuit is safely supplied here), contactors Q1 and Q2 are deactivated immediately. If all-pole disconnection is configured, Q2 immediately connects the island neutral conductor to the protective earth using the NC contacts (= normally closed contacts).

Otherwise, the KOSTAL Energy Meter used in the system diagnoses a faulty grid condition and communicates this to the PLENTICORE G3

The now deactivated contactors and the activated interlock relay report their statuses back to the PLENTICORE G3 via corresponding auxiliary contacts (= digital input In1) and the PLENTICORE G3 carries out a plausibility check.



Backup power operation is only started when all three phases have failed!

Backup power operation

The backup power mode is "started". The PLENTICORE G3 builds up its stand-alone mains voltage after approx. thirty seconds (30 s) and then supplies the loads connected to terminal strip X3 with backup power.

Network recovery

The Energy Meter installed in the system detects when the mains power is restored or the mains fault is rectified. This communicates the information to the PLENTICORE G3. Once the plausibility check has been carried out, it terminates the Backup power mode and deactivates the interlocking relay K1, mains contactor Q1 and earthing contactor Q2 (with all-pole disconnection) are energized, the loads on terminal strip X3 are supplied with voltage again.

The PLENTICORE G3 detects the mains voltage at its mains connection terminals and synchronizes itself back to the public mains according to the country-specific mains parallel conditions. The entire process takes approx. 1 minute (60 s).



Fire hazard due to short circuit!

All loads connected to X2 are always parallel to the grid and are always subject to the grid conditions.

4. TRANSPORT AND STORAGE

4.1 Delivery condition

Check the mains switch boxes for damage in their packaging. Observe the following instructions if the packaging is damaged:

- Make a note of the damage on the shipping documents and have the driver countersign them.
- Inform your wholesaler.
- Describe the damage in detail and take pictures of the damage.

4.2 Storage

The mains switch box must be stored in a dry, clean and cool place. The following criteria must be observed:

- The ambient temperature must be between -25°C and +55°C and must not exceed a short-term (up to 24 hours) storage temperature of 70°C under any circumstances.
- The mains switch box must not be stored together with flammable materials. The distance should be at least 2.5 m.
- Avoid direct sunlight and heat.

5. INSTALLATION



Note

Installation, connection and maintenance work may only be carried out by trained electricians (e.g. electricians, electrical system fitters, electromechanics, industrial electricians).

5.1 Scope of delivery

Quantity	Description
1	Mains switch box - variant 10017468 or 10017469
1	User manual
3	M40 cable gland incl. locknut
4	M32 cable gland incl. locknut
2	M25 cable gland incl. lock nut
4	M16 cable gland incl. locknut
2	Split molded sealing insert GFD25 (for RJ45 plugs - to be used in M25 cable glands)
1	"Dangerous voltage" warning sticker
1	Sticker "Indication of an off-grid storage system"
1	Set of jumpers (for configuration of mains disconnection)
1	Cover strip for Ethernet communication cables (when Energy Meter is used in the mains switch box)
1	Set of cover caps for fastening screws



Note

The scope of delivery does not include an energy meter!

MANUAL

5.2 Mounting the mains switch box

5.2.1 Installation location

⚠ DANGER

Danger to life due to fire and explosion!

- Do not install the mains switch box on a flammable surface!
- Do not install the mains switch box in areas where highly flammable substances are present!
- Do not install the mains switch box in areas where there is a risk of explosion!

Ensure that the following ambient conditions are observed at the installation site:

- The environment must be free of explosive gases, vapors or flammable materials. The mounting surface must be fireproof. Observe the local fire protection guidelines.
- The base is suitable for the weight and dimensions.
- The installation location is accessible at all times.
- The ambient temperature must be within the range of 0 ... 40°C. The recommended ambient temperature is 15 ... 30°C.
- The installation location is not exposed to direct sunlight or direct weathering.
- For indoor installation only.
- The installation location is protected from splashing water.

5.2.2 Mounting position

Install the mains switch box in a vertical position.

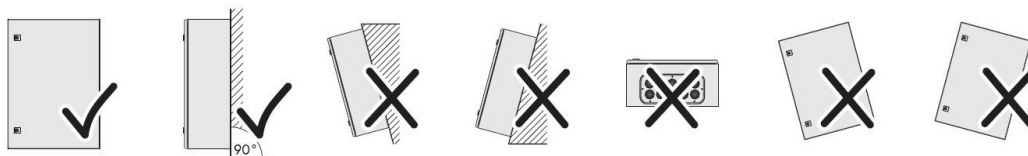

5.2.3 Minimum distances

Observe the minimum distances shown in the illustration during installation:

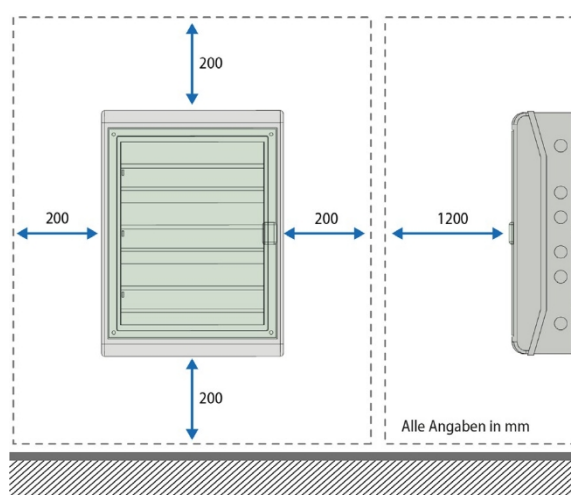

5.3 Connecting the mains switch box

5.3.1 Cable entry and connections

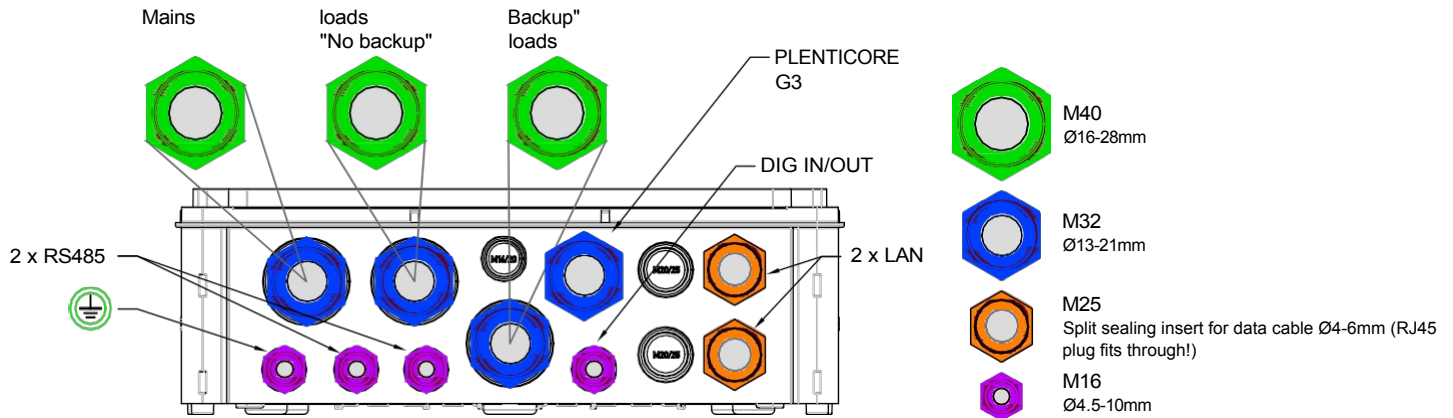

Terminal strip	Cable entry	Clamping range [mm]	Strand type	max. cross-section [mm ²]	Stripping length [mm]	Ferrule
X1 - Mains	M32 M40	13 - 21 16 - 28	solid fine stranded/multi-stranded fine stranded	16	18 - 20	-
				25		-
				16		✓
X2 - Loads without backup	M32 M40	13 - 21 16 - 28	solid fine stranded/multi-stranded fine stranded	16	18 - 20	-
				25		-
				16		✓
X3 - Loads with backup	M32 M40	13 - 21 16 - 28	solid fine stranded/multi-stranded fine stranded	16	18 - 20	-
				25		-
				16		✓
LAN data line	2 x M25	Split sealing insert for RJ45 plugs		acc. KOSTAL specifications		
RS485 data line	2 x M16	5 - 10		acc. KOSTAL specifications		
X4 - PLENTICORE G3 Power connection	M32	13 - 21	solid fine stranded/multi-stranded fine stranded	10	13 - 15	-
				10		-
				6		✓
X5 - PLENTICORE G3 Communication connection	M16	5 - 10	solid fine stranded	2,5	9 - 11	-
			fine stranded	2,5		-
			fine stranded	1,5		✓
PE	M16	5 - 10	solid fine stranded/multi-stranded fine stranded	16	18 - 20	-
				25		-
				25		✓

MANUAL

5.3.2 Connections to the terminal strips

The terminal strips are located in the lower area of the mains switch box. The cable entries should therefore also be made on the lower flange of the housing (use knockouts).

- X1 Mains connection or post-metering area
- X2 "normal" consumer loads, NOT backup-supported
- X3 Backup loads
- X4 PLENTICORE G3 - Power connection
- X5 PLENTICORE G3 - Communication connection
- X6 Base terminal strip (no connection - only set jumper for all-pole or three-pole disconnection configuration)

Delivery status

Terminal strip X6 is located in the upper right-hand area of the mains switch box and is a pure support point terminal strip!



The inlets are closed no clamping possible

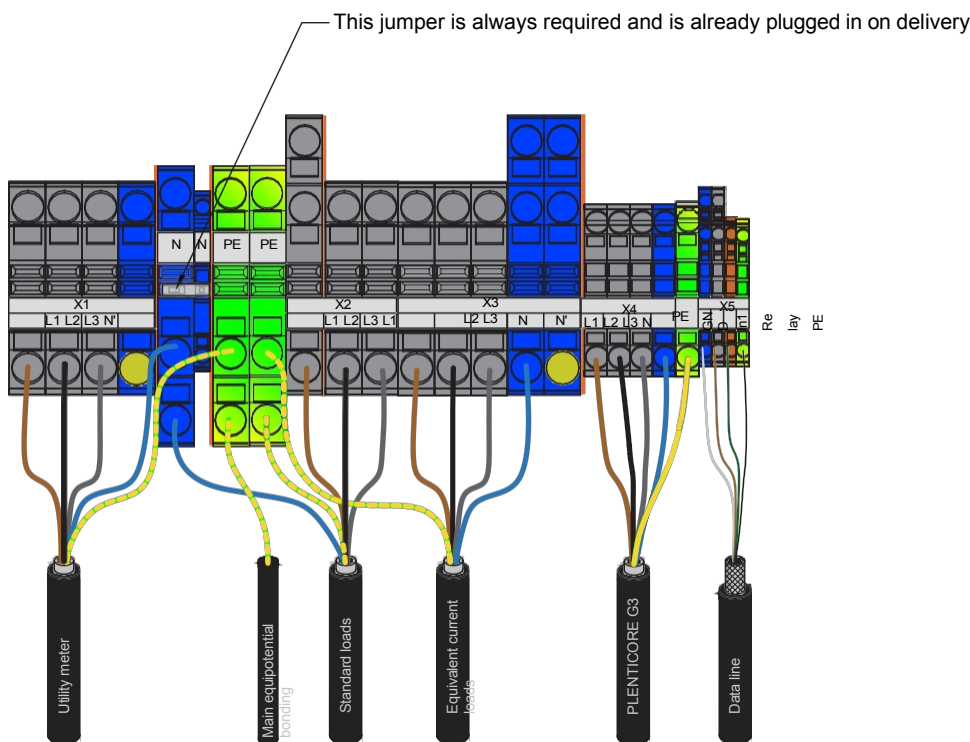

5.3.3 Configuration of the mains disconnection operating mode

Jumpers must be positioned differently depending on the operating mode. A distinction is made between the following operating modes:

- All-pole disconnection
 - Neutral conductor is switched via the mains isolating contactor (Q1)
 - Earthing device (contactor Q2) is activated in stand-alone mode
- Three-pole disconnection
 - Neutral conductor is continuous
 - Earthing device (contactor Q2) is NOT activated in stand-alone mode

ATTENTION

The configuration must be carried out once before commissioning the mains switch box when it is switched off. Before configuration, make sure of the mains connection type. With supplying TT mains, you may only disconnect all poles! TN-C loads are not permitted under any circumstances.

For supplying TN-C systems, the neutral conductor and protective conductor must be separated on the mains side BEFORE connection to terminal strip X1!

MANUAL

All-pole disconnection

"small" jumper - X6 - 2/3

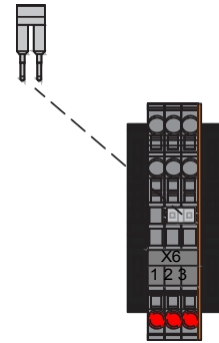

"large" jumper - X3 - N/N'

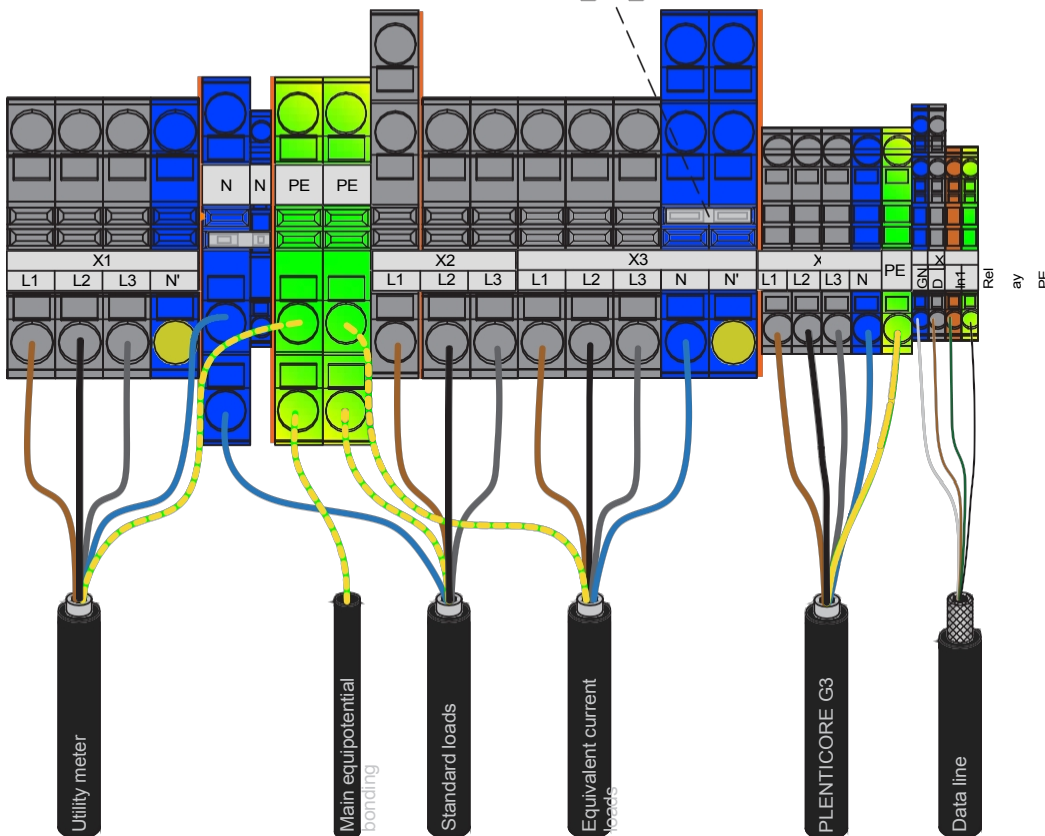
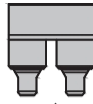

Three-pole disconnection

"small" jumper - X6 - 1/2

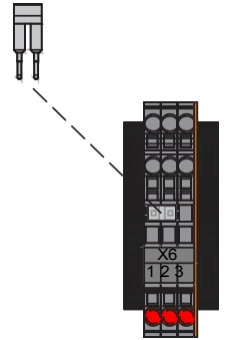

"large" jumper - X1 - N'/N

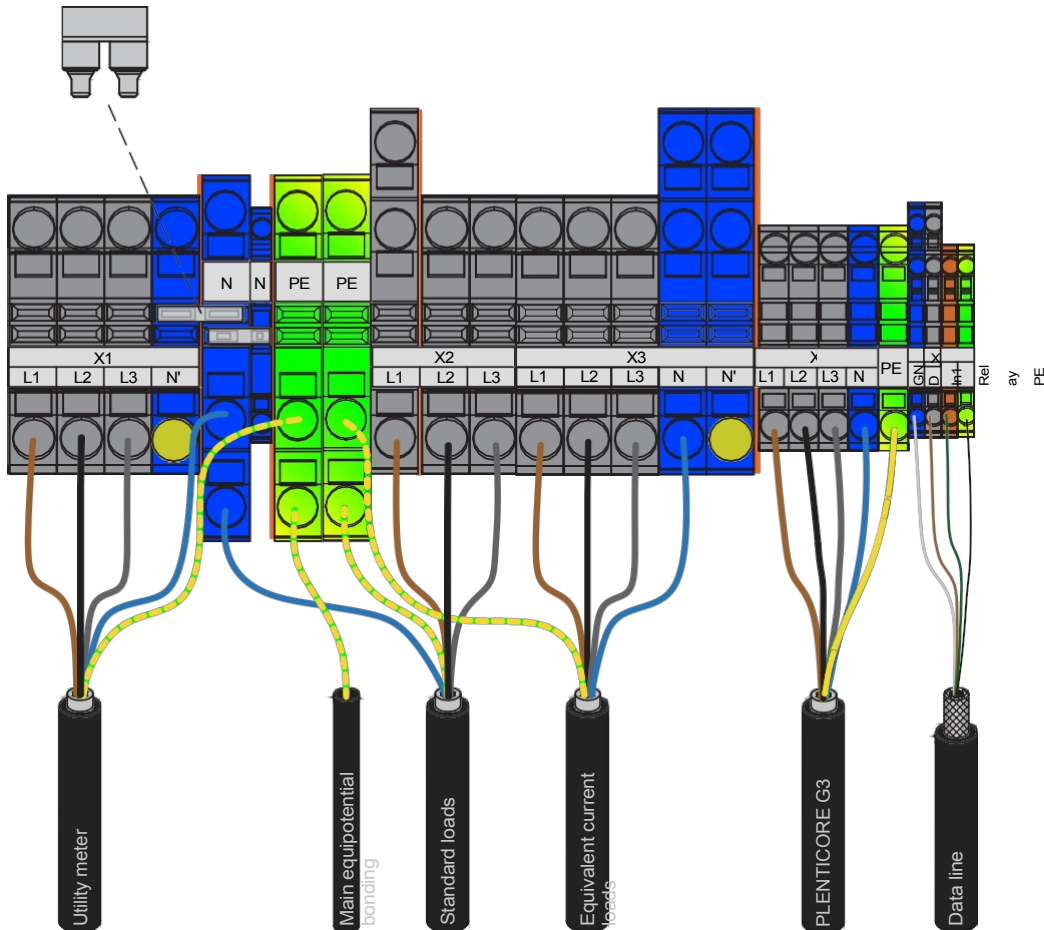

MANUAL

5.3.4 Installation of a KOSTAL Energy Meter

Depending on the system configuration and system planning, a KOSTAL Energy Meter can be installed in the grid switching box.

To do this, you must remove the screw terminals located in the mains switch box on the LEFT and insert the corresponding Smart Meter. Refer to the relevant KOSTAL documentation for information on the correct communication connection.

An energy meter is not included in the scope of delivery! A list of meters compatible with the PLENTICORE G3 including pin assignment can be found in the KOSTAL Solar Electric download area at www.kostal-solar-electric.com/download.

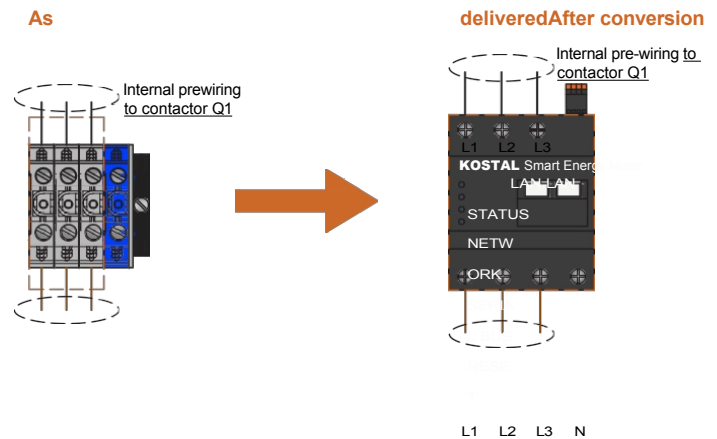

The screw-type feed-through terminals can be loaded with rated current. This means that the mains switch box can of course also be operated with an externally installed energy meter.

During installation, ensure that the Energy Meter is positioned correctly in relation to the cover strips of the installation distributor. Use the supplied pre-milled cover strips for the LAN connection to feed the cable through.

⚠ ATTENTION

The maximum permissible torque at the power terminals of the Energy Meter is 2 Nm!

5.3.5 Installation of circuit breaker and residual current device for PLENTICORE G3

The fuses for the PLENTICORE G3 can be integrated into the mains switch box if they are not installed in a separate distribution board on site. To do this, you can remove the screw-type feed-through terminals located in the mains switch box on the RIGHT and insert the appropriate fuse elements.

The maximum circuit breakers that can be used are KOSTAL according to the manufacturer:

- PLENTICORE G3 "S" max. B16/C16
- PLENTICORE G3 "M" max. B25/C25
- PLENTICORE G3 "L" max. B32/C32

If you require an additional residual current circuit breaker:

- Switch-off times for automatic switch-off in the event of a fault are not adhered to (e.g. in the TT network)
- for fire protection reasons

this can also be used. We then recommend connecting miniature circuit breakers and residual current circuit breakers with a suitable comb bridge. The pre-wiring to the screw-type feed-through terminals is assembled in such a way that it is suitable for all combinations. A total of seven DIN sub-units (approx. 125 mm) are available for installation.

Width of a three-pole miniature circuit

breakerThree

subunits Width of a four-pole residual current circuit breaker

Four subunits

MANUAL



Note

Observe the tightening torques to be observed for the corresponding components of your choice!

Example 1: Use of a 3-pole circuit breaker

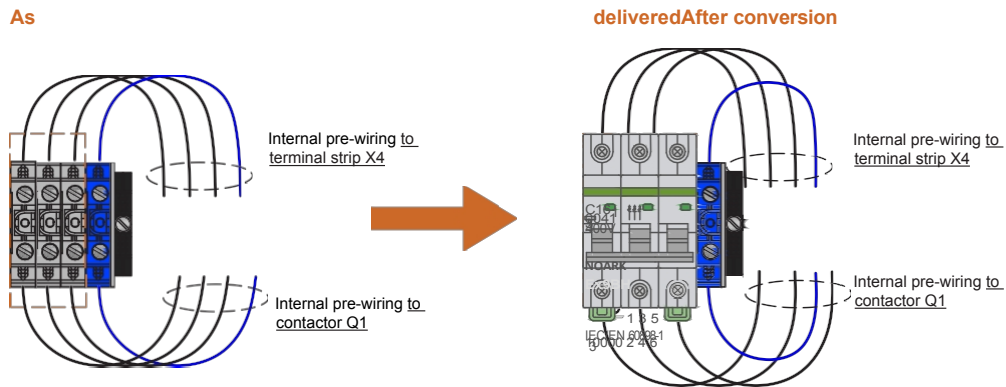

Example 2: Use of a 3-pole circuit breaker + residual current circuit breaker (N connection on the right)

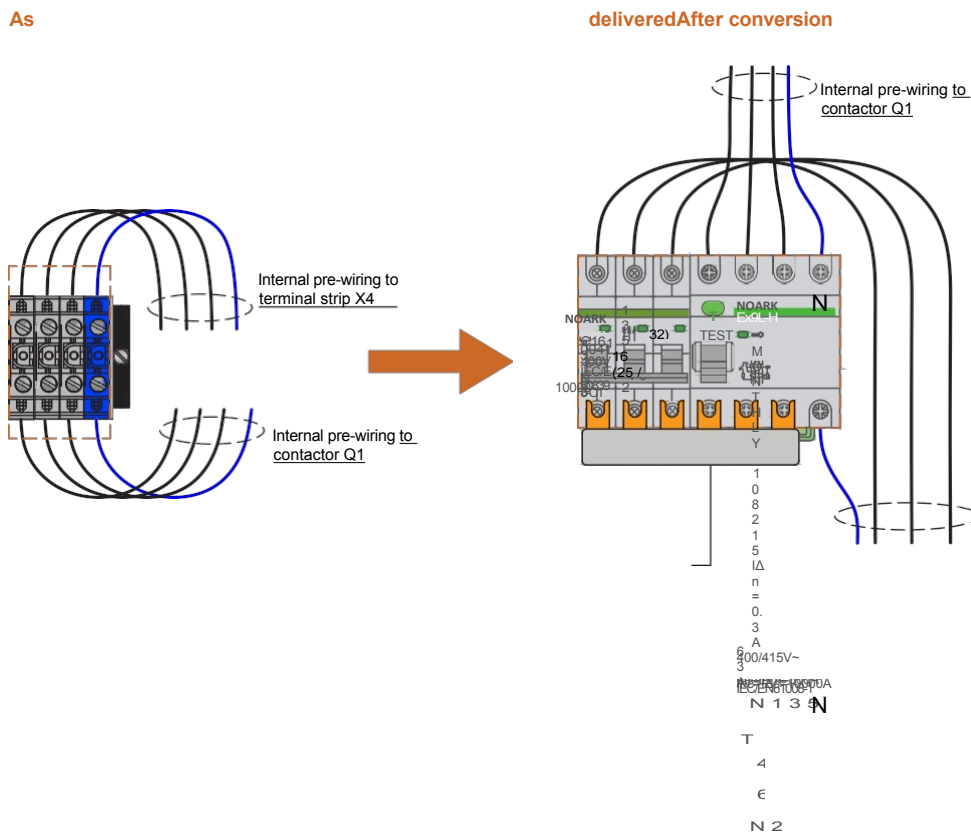

Recommendation: Use of a phase busbar (3-
phase) for a rated continuous current of
63A (10mm² Cu)
but in principle stranded bridges are also possible (use H07V-K 10mm²)

MANUAL

Example 3: Use of a 3-pole circuit breaker + residual current circuit breaker (N connection on the left)

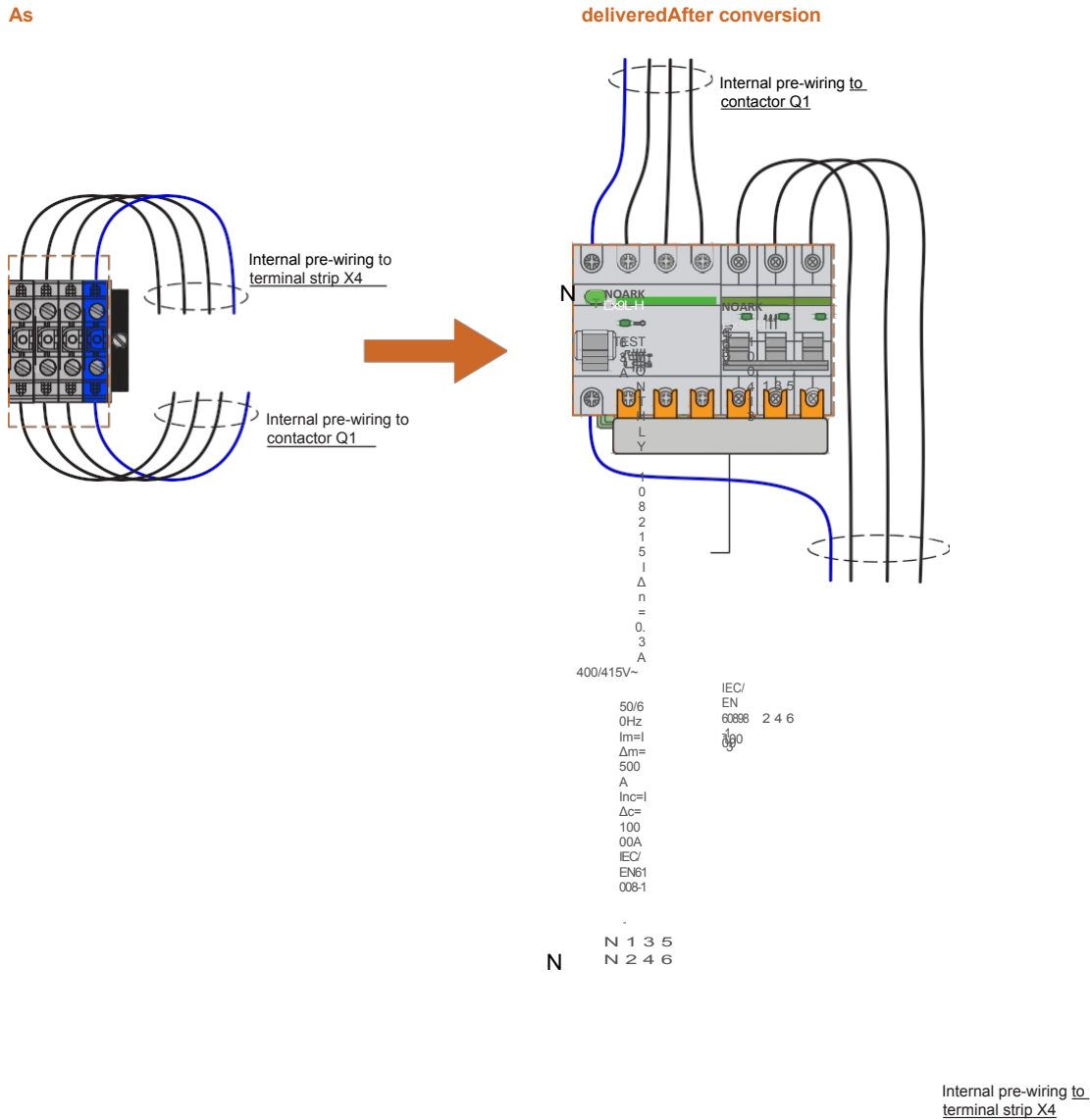

Recommendation: Use of a phase busbar (3-phase) for a rated continuous current of 63A (10mm² Cu) but in principle stranded bridges are also possible (use H07V-K 10mm²)

5.3.6 Connecting power and control cables

DANGER

Danger to life due to high voltages!

Components in the mains switch box are under dangerously high voltage during operation. Installation, connection and maintenance work may only be carried out by trained electricians (e.g. electricians, electrical system fitters, electromechanics, industrial electricians).

EVU meter

(X1)

- www.enwitec.eu Standard loads - no support in backup mode (X2)
- Backup power loads - backup-supported (X3)
- KOSTAL PLENTICORE G3 (X4)

Maximum connection cross-sections on the spring-cage terminals

Terminal strip	Strand/core type	max. cross-section [mm] ²	Stripping length [mm]
X1/X2/X3	Solid/multi-stranded Flexible stranded	16	18 - 20
	finely stranded with ferrule	25	
		16	
X4	solid fine stranded	10	13 - 15
	finely stranded with ferrule	10	
		6	

MANUAL

5.3.7 Connecting the data cable

The mains switchover box is connected to the PLENTICORE G3 via the data cable.



Note

When connecting the data cable to the KOSTAL PLENTICORE G3, follow the instructions in the PLENTICORE G3 installation manual regarding the specification of the data cable and the maximum permissible length!

Maximum connection cross-sections on the spring-cage terminals

Terminal strip	Strand/core type	max. cross-section [mm] ²	Stripping length [mm]
X5	solid fine stranded	2,5	9 -11
	finely stranded with ferrule	2,5	
		1,5	



Note

Connect the shield of the data cable to the PE terminal of terminal strip X5 (one-sided shielding = optimum protection against capacitive interference coupling)!

5.3.8 Connecting the protective conductor

WARNING

The local potential equalization (main earthing busbar) must be connected to the PE terminal block of the mains switch box! With a 5-core supply cable to X1 (L1/L2/L3/N/PE), no separate cable needs to be laid to the equipotential bonding bar. However, if a 4-core supply cable (e.g. in the TT network) is installed, a separate cable (min. Cu-16mm²) must be routed to the main equipotential bonding bar!



Note

The mains switch box itself corresponds to protection class II. The "PE" terminals in the connection area are not used for protective earthing of the housing of the mains switch box!

6. WIRING DIAGRAMS OF THE TWO VARIANTS

Variant 10017468

PLENTICORE G3 Communication

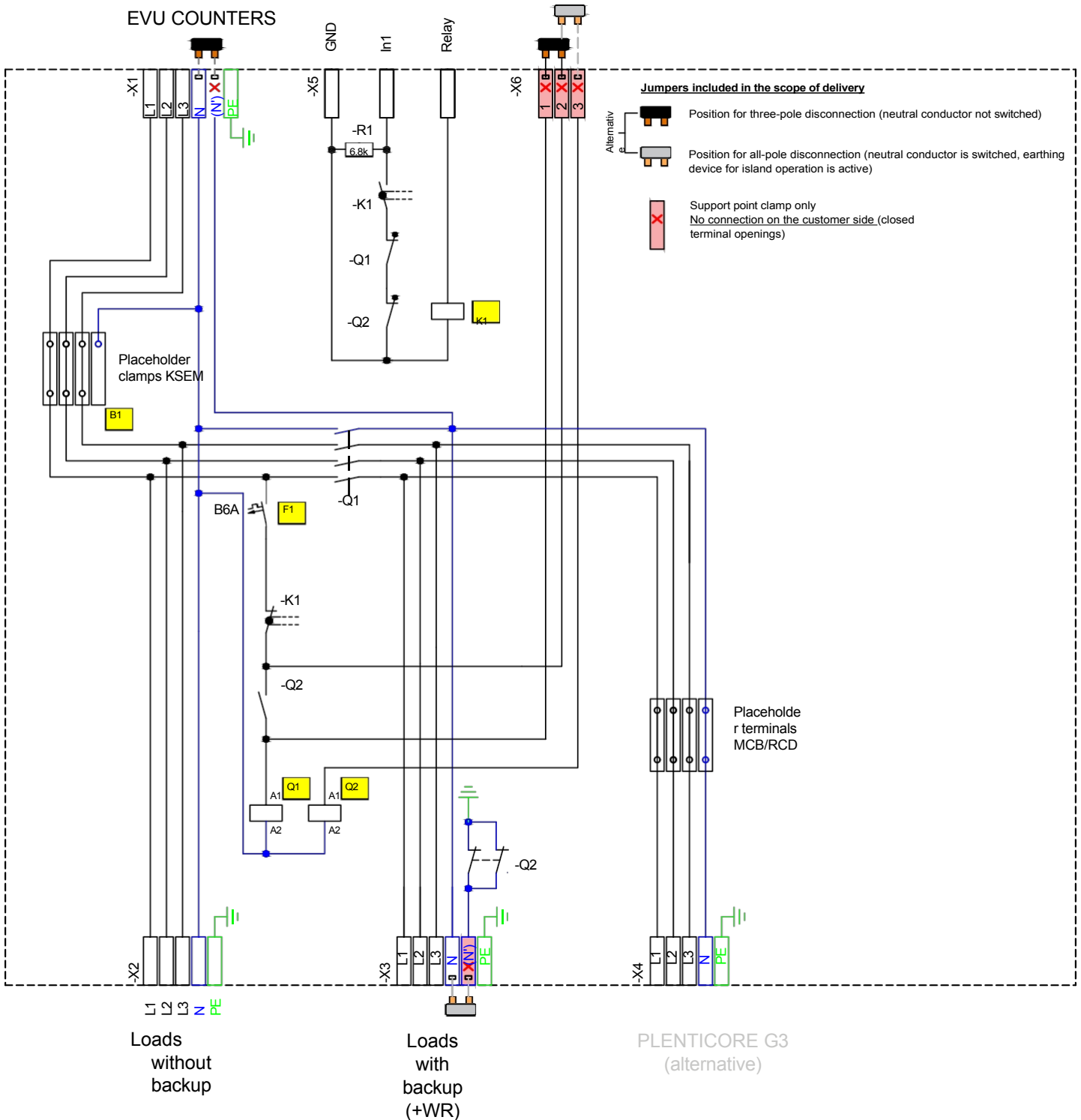

MANUAL

Variant 10017469

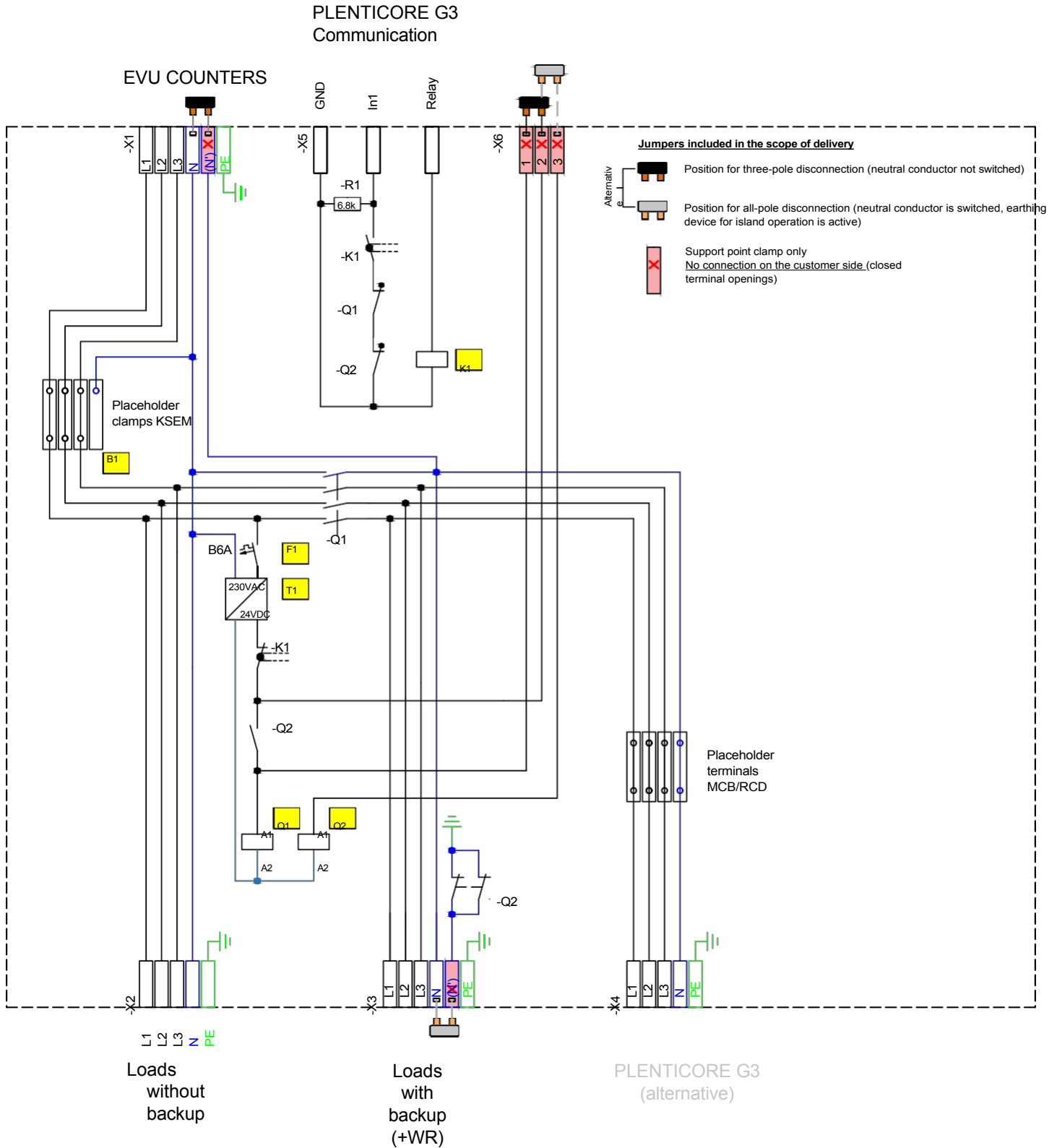

6.1 Wiring environment

Graphic from document "Freigegebenes Zubehör / Released accessories" from KOSTAL.

ENWITEC - automatische Netzumschaltbox
ENWITEC - automatic Grid switch box

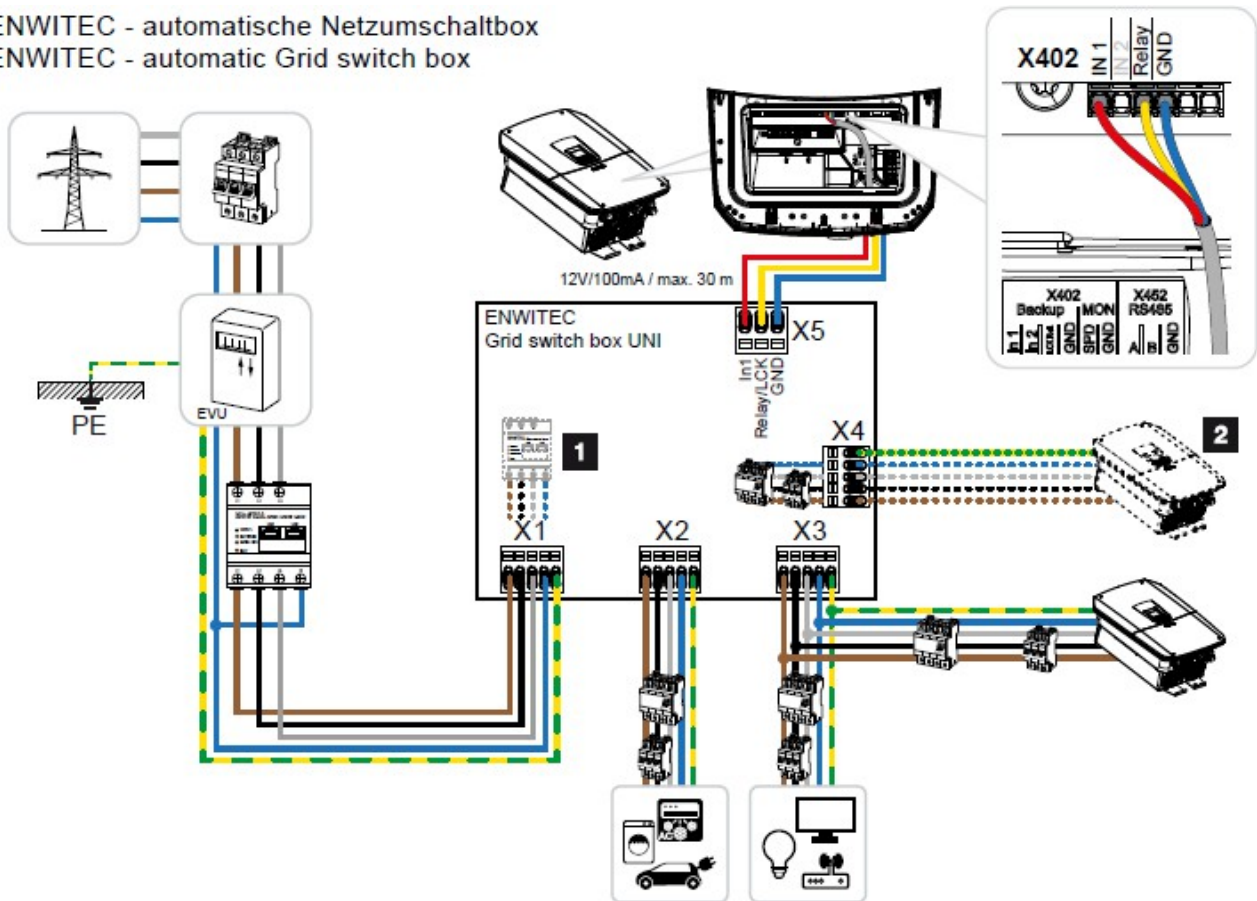

1) The KOSTAL Smart Energy Meter can also be installed directly in the Backup Box as an option.

2) The inverter can be connected either via connection terminal X3 (external in the sub-distribution board) or directly to X4 of the Backup Box. If the inverter is connected to X4, the RCD and the circuit breaker must be integrated in the Backup Box.

MANUAL

7. COMMISSIONING

7.1 Maximum currents and ambient temperature

During commissioning, the maximum currents must be taken into account in conjunction with the expected ambient temperature.

⚠ ATTENTION

To prevent premature ageing of the components and malfunctions of the mains switch box, e.g. unintentional tripping of circuit breakers due to high temperatures, the operating currents and ambient temperature must remain within the permissible limits!

Mains connection value max. 63 A Fuse	
Max. permissible ambient temperature*	40°C / 25°C
I_B via terminal strip X2 not backup-supported	50 A
I_{nq} via terminal strip X3 backup-supported	30 A (43.5 A**)
* Values dependent on operation with or without ventilation valves	
** with ventilation valves	

Short-term peak currents of the load/PV system can and may be higher!

7.2 Prerequisite for commissioning

- The KOSTAL inverter is installed in accordance with the KOSTAL operating instructions.
- The battery storage system is set up according to the manufacturer's documentation.
- The Energy Meter (KSEM, KEM-C or KEM-P) is installed as described in the KOSTAL operating instructions.
- The mains switch box is permanently mounted.
- All required cables are correctly installed and connected.
- All tests to be carried out in advance in accordance with the national/local installation regulations for fixed electrical equipment (e.g. in accordance with DGUV Regulation 4) have been completed.
- The protective earth conductor to the main earthing busbar is connected.
- All necessary insulation tests have been carried out.

7.3 Procedure for commissioning

Carry out the following steps to commission the mains switchover box together with the KOSTAL PLENTIÖRE G3 for backup power mode:

1. Activate the circuit breaker F1 in the mains switch box, provided that the mains voltage is present at terminal strip X1.
2. Switch on the mains voltage via the circuit breaker of the inverter.
3. Switch on the battery storage system.
4. Set the DC switch on the inverter to ON.
5. Carry out the initial commissioning of the inverter using the wizard.

6. After successful commissioning, replace the housing cover of the mains switch box and screw the cover on.
7. Then close the hinged lids.
8. Attach the "Dangerous voltage" sticker included in the scope of delivery to the side of the mains switch box housing.
9. It is best to affix the sticker "Reference to an off-grid storage system" included in the scope of delivery to the low-voltage main distribution board.



"Dangerous voltage" sticker

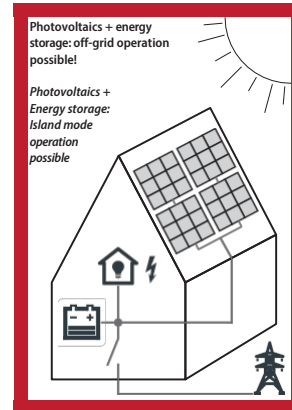

"Indication of an off-grid storage system" sticker

7.4 Activation of the backup power mode

To be able to use backup power mode, it must first be configured in the inverter. Please select the "Backup Box" as a system component at the start of initial commissioning. You also need a connected energy meter and a battery to use backup power mode.

If you install the grid-connection box after the inverter has been commissioned, you must first reset the operating mode in the PLENTICORE G3 service menu, restart the inverter and carry out commissioning again as described above.

Betriebsart

Verbundene Systemkomponenten



PV String



Energiezähler



Batterie



KOSTAL BackUp
Switch



Backup Box

■ MANUAL

8. TROUBLESHOOTING

In the event of a malfunction, please have the mains switch box checked by a qualified electrician. Qualified electrician:
Please contact the enwitec service department!

9. DE-ENERGIZE THE MAINS SWITCHOVER BOX

Carry out the following steps to de-energize the mains switch box:

1. Turn the DC switch on the PLENTICORE G3 to OFF.
2. A battery is always required for backup operation! Therefore, switch off the battery storage system! You will find a detailed description of this in the battery manufacturer's operating instructions.
3. Deactivate the AC circuit breaker of the inverter.
4. Check whether the inverter is now de-energized and secure the device against being switched on again.
5. De-energize the X1 connection to which the public mains is connected. To do this, disconnect the fuse elements that are connected between the public mains and the mains switch box.
6. Check that there is no voltage at connection X1 and secure the connection against being switched on again.

10. MAINTENANCE AND CLEANING

You should regularly check the function and safety of the mains switch box. Please observe the national regulations, which vary from country to country.

Maintenance according to DGUV

In Germany, for example, according to DGUV regulation 3 §5, electrical systems and stationary electrical equipment in "operating facilities, rooms and systems of a special kind" (DIN VDE 0100-712 for PV systems) must be checked ONCE A YEAR by a qualified electrician!

Check the residual current circuit breaker (if installed)

A residual current circuit breaker installed in the mains switch box must be checked regularly by the system operator for its basic function (test button).

Cleaning

Depending on the installation location and the ambient conditions, external soiling will occur to a greater or lesser extent. Clean carefully with a damp cleaning cloth! Never open the housing when cleaning and only clean with the hinged cover closed!

11. DISPOSAL

Dispose of the mains switch box in accordance with the current national and international rules and regulations in your country. The mains switch box must not be disposed of with household waste.

In the European Union, the handling of electronic waste is regulated by the WEEE Directive, which is implemented in Germany, for example, in the Electrical and Electronic Equipment Act (ElektroG). Recycling or reusable material centers take over the professional disposal of electronic waste.

12. TECHNICAL DATA

Variant 10017468

POSSIBLE COMBINATIONS OF NET SHAPES

Grid connection point	Consumer system in mains operation	Setting options via jumpers
TN-C	TN-S	three-pole (recommended) or all-pole
TN-C	TN-C	FORBIDDEN!
TN-S	TN-S	all-pole
TT	TT	all-pole

NOMINAL VALUES

Rated voltage U_e	[V]	3PH - 230/400
Rated insulation voltage U_i	[V]	400
Rated impulse withstand voltage U_{imp}	[kV]	4
Rated frequency f_n	[Hz]	50/60+/-5%
Conditional rated short-circuit current I_{cc}	[nA]	10
Rated current I_{ng} with rated load factor RDF 1 and t_a 40°C - via Q1 and X3	[A]	30
Rated current I_{ng} with rated load factor RDF 1 and t_a 25°C - via Q1 and X3	[A]	43,5 ¹
Short-term maximum operating current I_b via X2	[A]	≤ 63
Maximum thermal operating current I_b via X2	[A]	50
Total rated current of the mains switch box I_{nA}	[A]	$I_{ng} + I_b \leq 63$
Mains disconnection		all-pole or three-pole
Max. grid-side backup fuse value (gL/gG)	[A]	63
Standby losses, approx.	[W]	6

¹ Ventilation valves (passive) required; this reduces the protection rating from IP65 to IP44 (see accessories).



MANUAL

SWITCHING TIMES MAINS / STAND-ALONE OPERATION (BACKUP POWER)

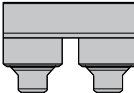

Mains operation to standby power operation - Mains failure	[s]	~ 30
Backup power operation to mains operation - Mains recovery	[s]	~ 60

CONFIGURATION Mains disconnection using plug connectors (included in the scope of delivery)

THREE-POLE

X1	inserted between N-N'	16(25) mm ²	
X6	plugged between 1-2	1.5(2.5) mm ²	

ALLPOLIG

X3	inserted between N-N'	16(25) mm ²	
X6	inserted between 2-3	1.5(2.5) mm ²	

POWER CONNECTION PLENTICORE G3 (alternative)

When connecting the PLENTICORE G3 in the mains switchbox and external fuses (residual current circuit breaker and/or Circuit breakers are available on site) → Connection to X3 or X4 (see chapter 6.1).

When connecting the PLENTICORE G3 in the mains switch box and internal fuse protection → Connection exclusively to X4: The placeholder terminals upstream of X4 must be removed on site and residual current circuit breakers and/or miniature circuit breakers must be installed,

7 sub-units (1 TE = 17.8 mm) are available. Recommendation: In the TT network (all-pole disconnection), install a 300 mA residual current circuit breaker to comply with the protective measure "Automatic disconnection of the power supply". For the rated currents of the miniature circuit breakers, please refer to the KOSTAL recommendations for the PLENTICORE G3 power classes.

INSTALLED COMPONENTS

F1	Circuit breaker for control circuit	[A]	B6
Q1	Mains isolating contactor	AC1 [A]	55
Q2	Contactor for earthing device	AC1 [A]	30
K1	Interlocking relay (positively driven contacts)	AC1 [A]	10

GENERAL		• applicable /- not applicable
Dimensions WxHxD (without screw connections)	[mm]	315 x 600 x 145
Weight, approx.	[kg]	7,5
Operating temperature range t_a with RDF1 and I_{ng} 43.5 A	[°C]	-25...+25
Operating temperature range t_a with RDF1 and I_{ng} 30 A	[°C]	-25...+40
Temperature - transportation/storage (24 hours 70°C)	[°C]	-25...+55
Humidity - condensing permitted	-/-	-
Humidity - permissible range	[%]	5...95 % (for IP65) / 5...80% (for IP44)
Max. Installation height above N.N.	[m]	2000
Protection class IP (EN 60529)		65 - as delivered / 44 - with ventilation valves
Outdoor suitability (protected area)	-/-	-
Installation type		Indoor area
Protection class (EN 61140)		II
Housing material		Polycarbonate
RoHS-compliant (2011/65/EU)	-/-	-
Housing color		similar to RAL 7035
Lid		Transparent hinged door
Mounting type		Wall mounting
Closure type		without tools
OTHER		
Customs tariff number		85371098
ACCESSORIES		
Set of ventilation valves, to be used for $I_{nA} >$ approx. 30 A (max. 2 sets possible, at least 1 set required)		10017652 (enwitec)
Set consisting of: 2 x ventilation valve 2 x reducing insert 2 x locknut		036579 (LeGrand) M40/M32 M40

Variant 10017469

POSSIBLE COMBINATIONS OF NET SHAPES

Net	Consumer system in mains operation	Setting options via jumpers
TN-C	TN-S	three-pole (recommended) or all-pole
TN-C	TN-C	FORBIDDEN!
TN-S	TN-S	all-pole
TT*	TT*	all-pole

NOMINAL VALUES

Rated voltage U_e	[V]	3PH - 230/400
Rated insulation voltage U_i	[V]	400
Rated impulse withstand voltage U_{imp}	[kV]	4
Rated frequency f_n	[Hz]	50/60+/-5%
Conditional rated short-circuit current I_{cc}	[nA]	10
Rated current I_{ng} with rated load factor RDF 1 and t_a 40°C - via Q1 and X3	[A]	30
Rated current I_{ng} with rated load factor RDF 1 and t_a 25°C - via Q1 and X3	[A]	43,5 ¹
Short-term maximum operating current I_b via X2	[A]	≤ 63
Maximum thermal operating current I_B via X2	[A]	50
Total rated current of the mains switch box I_{nA}	[A]	$I_{ng} + I_b \leq 63$
Mains disconnection		all-pole or three-pole
Max. grid-side backup fuse value (gL/gG)	[A]	63
Standby losses, approx.	[W]	6





SWITCHING TIMES MAINS / STAND-ALONE OPERATION (BACKUP POWER)

Mains operation to standby power operation - Mains failure	[s]	~ 30
Backup power operation to mains operation - Mains recovery	[s]	~ 60

¹ Ventilation valves (passive) required; this reduces the protection rating from IP65 to IP44 (see accessories).
 * In coordination with the network operator.

CONFIGURATION Mains disconnection using plug connectors (included in the scope of delivery)

THREE-POLE

X1	inserted between N-N'	16(25) mm ²	
X6	plugged between 1-2	1.5(2.5) mm ²	
X3	inserted between N-N'	16(25) mm ²	
X6	inserted between 2-3	1.5(2.5) mm ²	

POWER CONNECTION PLENTICORE G3 (alternative)

When connecting the PLENTICORE G3 in the mains switch box and external fuses (residual current circuit breaker and/or Circuit breakers are available on site) → Connection to X3 or X4 (see chapter 6.1).

When connecting the PLENTICORE G3 in the mains switch box and internal fuse protection → Connection exclusively to X4: The placeholder terminals upstream of X4 are removed on site and residual current circuit breakers and/or miniature circuit breakers are installed, there are 7

sub-units (1 TE = 17.8 mm) are available. Recommendation: In the TT network (all-pole disconnection), install a 300 mA residual current circuit breaker to comply with the protective measure "Automatic disconnection of the power supply". For the rated currents of the miniature circuit breakers, please refer to the KOSTAL recommendations for the PLENTICORE G3 power classes.

INSTALLED COMPONENTS

F1	Circuit breaker for control circuit	[A]	B6
Q1	Mains isolating contactor	AC1 [A]	55
Q2	Contactor for earthing device	AC1 [A]	30
K1	Interlocking relay (positively driven contacts)	AC1 [A]	10
T1	Buffer power supply unit	[V]	24

MANUAL

GENERAL		• applicable / - not applicable
Dimensions WxHxD (without screw connections)	[mm]	315 x 600 x 145
Weight, approx.	[kg]	7,8
Operating temperature range t_a with RDF1 and I_{ng} 43.5 A	[°C]	-25...+25
Operating temperature range t_a with RDF1 and I_{ng} 30 A	[°C]	-25...+40
Temperature - transportation/storage (24 hours 70°C)	[°C]	-25...+55
Humidity - condensing permitted	-/-	-
Humidity - permissible range	[%]	5...95 % (for IP65) / 5...80% (for IP44)
Max. Installation height above N.N.	[m]	2000
Protection class IP (EN 60529)		65 - as delivered / 44 - with ventilation valves
Outdoor suitability (protected area)	-/-	-
Installation type		Indoor area
Protection class (EN 61140)		II
Housing material		Polycarbonate
RoHS-compliant (2011/65/EU)	-/-	-
Housing color		similar to RAL 7035
Lid		Transparent hinged door
Mounting type		Wall mounting
Closure type		without tools
OTHER		
Customs tariff number		85371098
ACCESSORIES		
Set of ventilation valves, to be used for $I_{nA} >$ approx. 30 A (max. 2 sets possible, at least 1 set required)		10017652 (enwitec)
Set consisting of: 2 x ventilation valve 2 x reducing insert 2 x locknut		036579 (LeGrand) M40/M32 M40

MANUAL

The product, Designation: 3PH_KOSTAL_BBD3(A)P_63A_FRT_AUT

Item number: 10017469

Manufacturer: enwitec electronic GmbH
Scherrwies 2
84329 Rogglfing

Description: Changeover device

to which this declaration refers complies with the following standards or normative documents:

EN 61439-1 Low-voltage switchgear and controlgear assemblies

EN 61439-2 Energy-switchgear combinations

EN 61439-3 Installation distributor for operation by laypersons (DBO)

and complies with the provisions of the following EC Directive(s):

Low Voltage Directive 2014/35/EU

Prohibited substances 2011/65/EU

(RoHS)

Test requirements for generating units OVE Guideline R25

Year of affixing the CE marking: 2024

Date of issue: 01.03.2024

enwitec electronic GmbH



Name / Signature

Johann Wimmer Management

NOTES

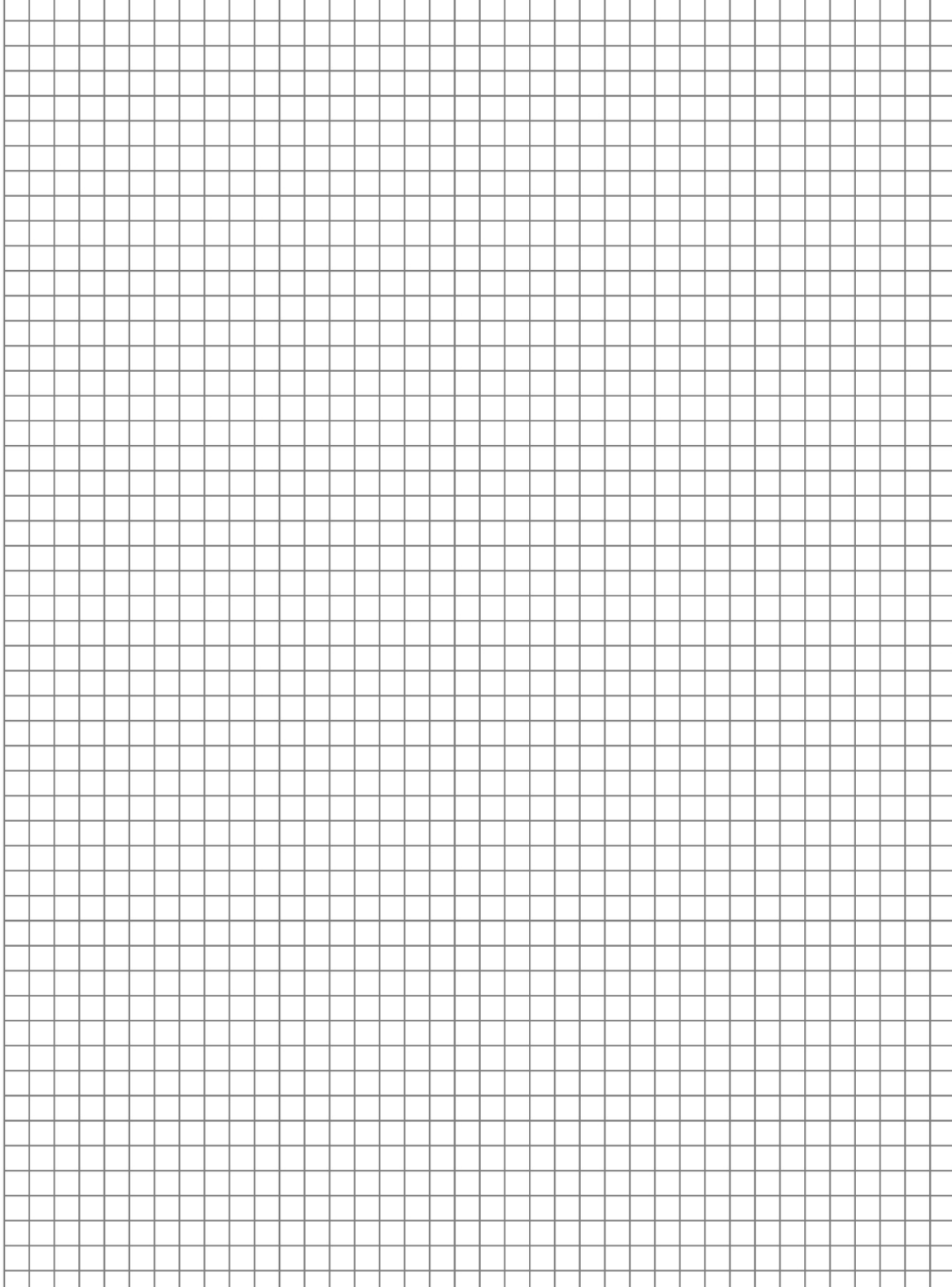

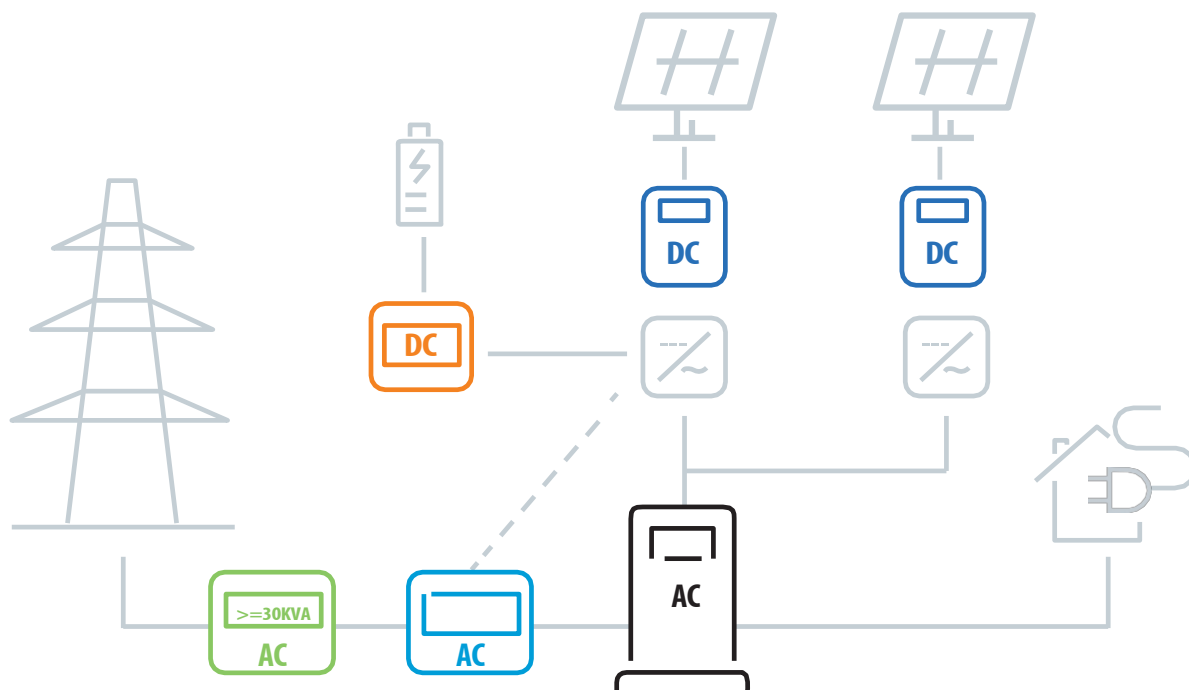

OUR SERVICES

GENERATOR CONNECTION BOXES, optional with:

- Overvoltage protection
- Switch-disconnector
- String fuses
- Strand monitoring

FIRE DEPARTMENT SWITCH (REMOTE-CONTROLLED SWITCH-DISCONNECTOR)

POWER SWITCHBOXES, for manufacturer systems:

- Fronius
- SMA
- LG
- and much more.

NETWORK AND SYSTEM PROTECTION:

- Mains and system protection
- Protection technology and EZA controller

BATTERY FUSES, optional with:

- Fusible links
- Circuit breaker/circuit breaker
- Overvoltage protection

AC DISTRIBUTOR:

- AC distributor General
- AC distributor with charging technology for e-mobility