



SIGENERGY

Business Energy Solution

Powering the future of business



Sigenergy focuses on developing cutting-edge home and business energy solutions, with products ranging from energy storage systems to solar inverters and EV chargers. Our world-class R&D team of hundreds of top industry experts shares the vision of making the world greener via continuous innovation. With global sales and services, we aim to become our customers' most trusted partner on their journey to a more sustainable future.

www.sigenergy.com

Disclaimer: The information in this file is provided on an "as is" basis. To the fullest extent permitted by law, Sigenergy Technology Co., Ltd. excludes all representations and warranties relating to this file and its contents or which is or may be provided by any affiliates or any other third party, including in relation to any inaccuracies or omissions in this file.

Version:20250918

CONTENTS

01 ABOUT SIGENERGY

02 PRODUCT

Business Energy Solution
Product Portfolio

03 TRUSTED PARTNER

Intelligent Manufacturing
Global Cases





SIGEN

Safe Intelligent Green Efficient New

Enjoy Green Energy

ABOUT SIGENERGY

Sigenergy focuses on developing cutting-edge home and business energy solutions, with products ranging from energy storage systems to solar inverters and EV chargers. Our world-class R&D team of hundreds of top industry experts shares the vision of making the world greener via continuous innovation. With global sales and services, we aim to become our customers' most trusted partner on their journey to a more sustainable future.

VISION

Enjoy Green Energy

MISSION

Be a distributed energy pioneer.
Build intelligent energy solutions with superior safety,
ultra simplicity, and outstanding performance.

SIGENERGY BUSINESS ENERGY SOLUTION

Optimal CAPEX

- Innovative DC coupling & built-in EMS for streamlined configuration
- Modular design & stackable installation enables flexible energy scaling
- Simplified installation process for time-saving and hassle-reduction

Reduced OPEX

- "Free" O&M Design, IP66 protection for worry-free outdoor deployment
- Industry-leading pack-level safety protection & system-level reliability
- Pack-level active balancing, no need for on-site SOC calibration

Higher Revenue

- Innovative DC coupling, 2% higher RTE, less conversion, more energy
- 2.0 DC/AC ratio, recapture the over-sized PV clipping for higher revenue
- Modular design, fast system recovery ensures higher system availability



SigenStack



Sigen Hybrid Inverter



SigenStor



Sigen Energy Gateway



Sigen Cloud & mySigen App

On-grid PV+ESS System

In scenarios with a stable grid power supply, the system intelligently optimizes energy utilization to maximize solar self-consumption and user benefits. When solar generation is abundant, excess energy is stored in the battery. When solar power becomes insufficient, the system seamlessly discharges the battery to power the loads, ensuring efficient energy management and enhanced economic returns.

Equipped with an integrated Energy Management System (EMS), Sigenergy solution supports multiple inverters operating in parallel without the need for an external data logger, enabling a simplified system architecture. Featuring a "Battery Ready" inverter, Sigenergy solution adopts a true DC-coupled architecture, maximizing energy conversion efficiency while significantly optimizing CAPEX (capital expenditures), slashing O&M cost, and enhancing system efficiency.

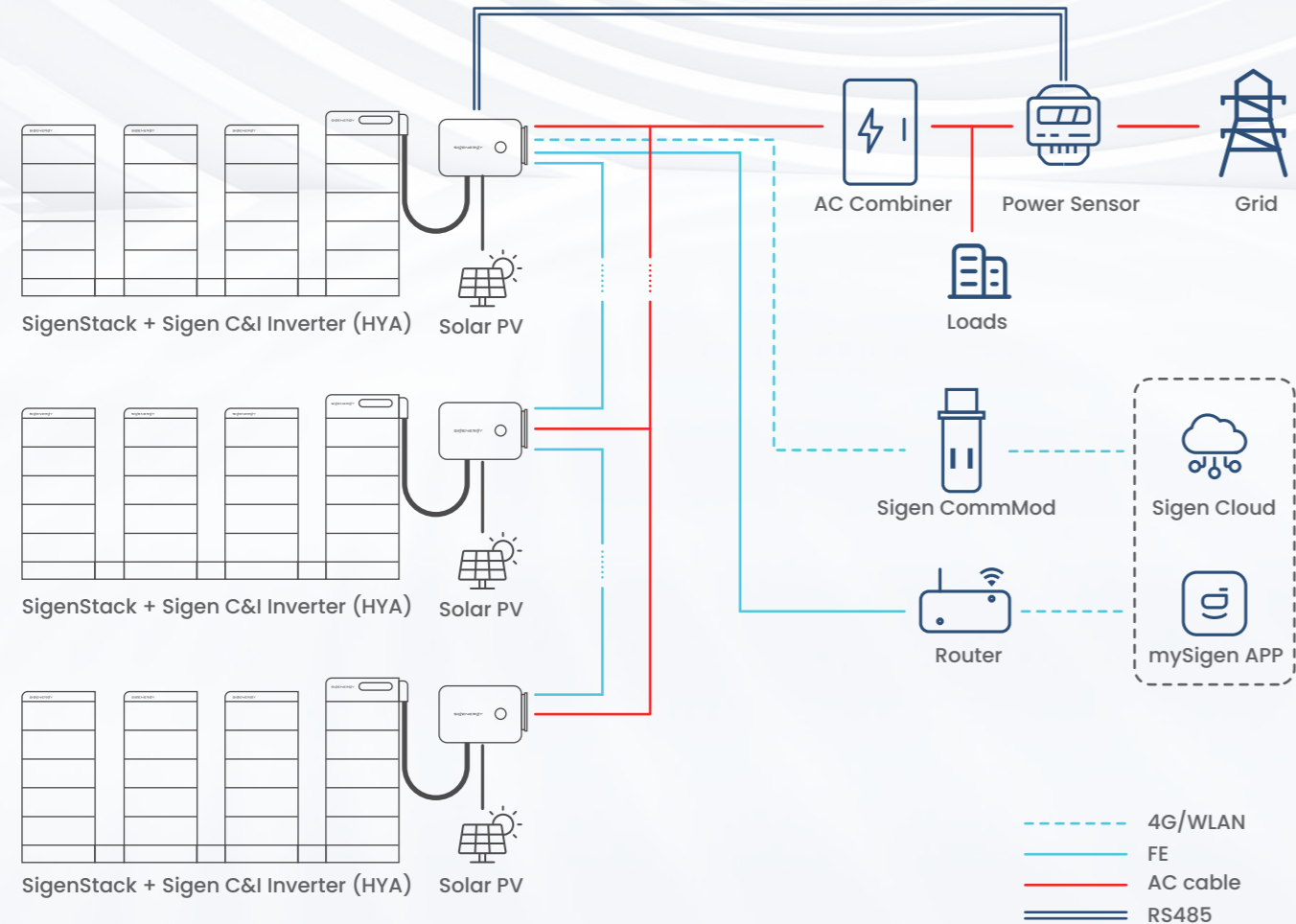

Micro-grid PV+ESS System

In microgrid scenarios, the system operates independently to ensure a continuous and reliable power supply. When solar energy is abundant, it powers the loads and charges the battery. When there is a power outages on the grid at night, the battery discharges to supply the loads. If both solar and battery energy are unavailable, a diesel generator automatically starts to maintain uninterrupted power. This seamless coordination among solar, battery, grid, and diesel generator guarantees stable and resilient energy for microgrid applications.

Multi-unit parallel connection through a gateway enables flexible system scaling from kilowatts to megawatts, supporting a wider range of microgrid sizes. Sigenergy DC-coupled microgrid solution streamlines system design, improves energy conversion efficiency, and delivers a robust, cost-effective, and reliable power solution for your business.

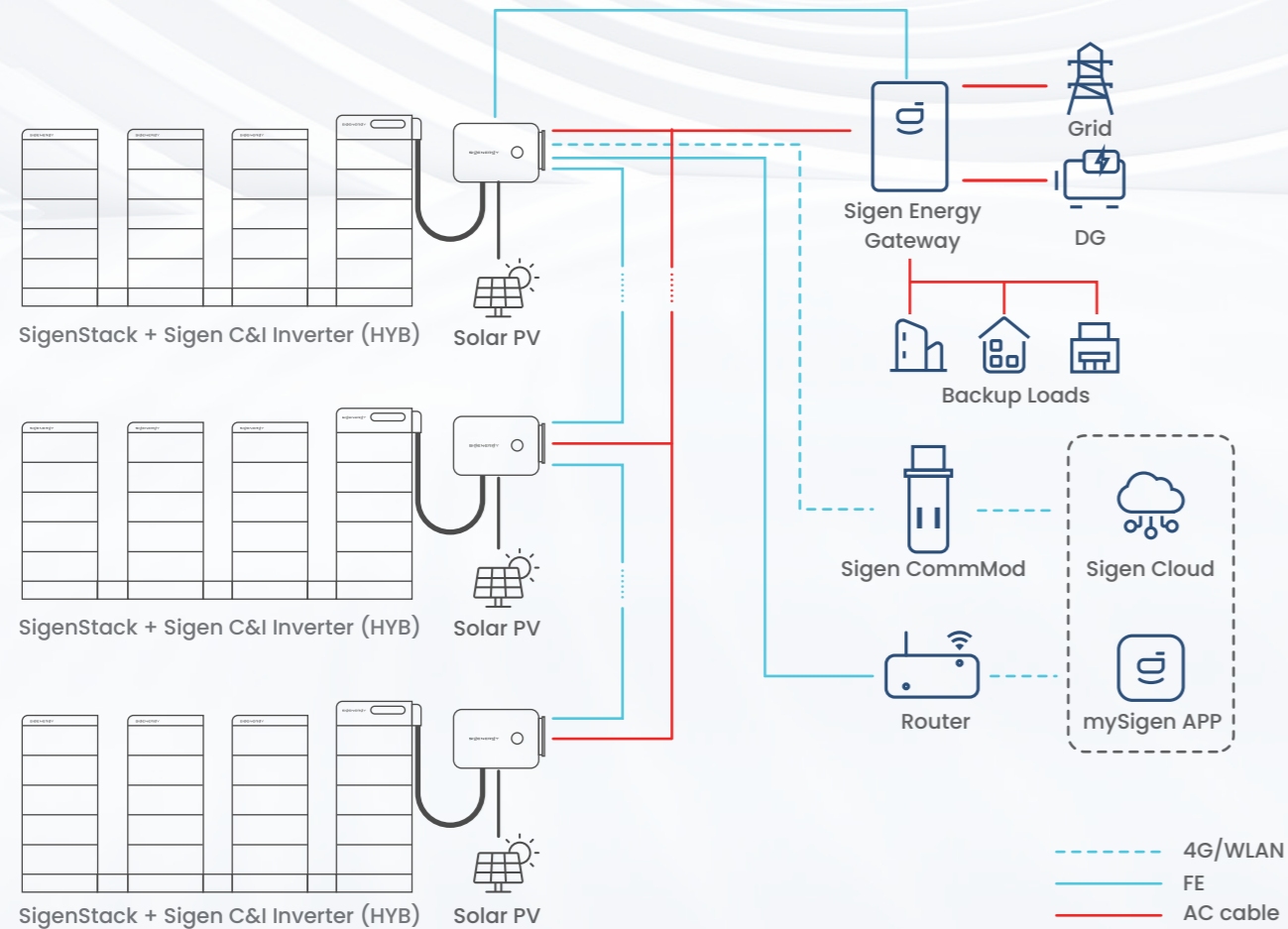

Sigen PV Inverter

50.0 / 60.0 / 80.0 / 100.0 / 110.0 / 125.0 kW



- Smaller and lighter, easier installation and transportation
- Built-in EMS, supports 100 units in parallel without data logger
- Industry-leading 500m AFCI, top-tier safety across applications
- On-site self-power supply, removes the need for temporary power
- IP66 protection rating, ensuring worry-free outdoor deployment

Sigen PV Inverter 50.0 / 60.0 / 80.0 / 100.0 / 110.0 / 125.0 kW

Sigen PV	50M1	60M1	80M1	100M1	110M1	125M1	Units	
DC Input								
Max. PV input power	100,000	120,000	160,000	200,000	220,000	220,000	Wp	
Max. DC input voltage							1,100	V
Nominal DC input voltage							600	V
Start-up voltage							180	V
MPPT voltage range							160 ~ 1,000	V
Number of MPP trackers	4	5	6	8	8	8		
Number of PV strings per MPPT							2	
Max. input current per MPPT							40	A
Max. short-circuit current per MPPT							60	A
AC Output								
Nominal output active power	50,000	60,000	80,000	100,000	110,000	125,000	W	
Max. output apparent power	55,000	66,000	88,000	110,000	121,000	137,500	VA	
Max. output active power (cosΦ=1)	55,000	66,000	88,000	110,000	121,000	137,500	W	
Nominal output current @380Vac	76.0	91.2	121.5	151.9	167.1	189.9	A	
Nominal output current @400Vac	72.5	87.0	115.9	144.9	159.4	181.2	A	
Max. output current @380/400Vac	83.6	100.3	133.7	167.1	183.8	208.9	A	
Nominal output voltage							380 / 400, 3W+(N)+PE	Vac
Nominal grid frequency							50 / 60	Hz
Power factor							0.8 leading ~ 0.8 lagging	
Total current harmonic distortion	THDi < 3%	THDi < 3%	THDi < 2%	THDi < 2%	THDi < 2%	THDi < 2%		
Efficiency								
Max. efficiency							98.6%	
European efficiency	98.3%	98.3%	98.3%	98.4%	98.4%	98.3%		
Protection								
Safety protection feature	DC reverse polarity protection, Insulation monitoring, Residual current monitoring, Arc fault circuit interrupter, AC overcurrent/overvoltage/short-circuit protection. Type II DC/AC surge protection, Anti-islanding protection							
General Data								
Dimensions (W / H / D)							918 / 640 / 340	mm
Weight	69	72	72	72	72	83	kg	
Nighttime power consumption							< 3.5	W
Storage temperature range							-40 ~ 70	°C
Operating temperature range							-30 ~ 60	°C
Relative humidity range							0% ~ 100%	
Max. operating altitude							5,000 (Derating at 4,000m)	m
PV connection type							MC4 (Max. 6 mm ²)	
AC connection type							OT / DT terminal (Max. 240 mm ²)	
Cooling							Smart air cooling	
Ingress protection rating							IP66	
Communication							WLAN / Fast Ethernet / RS485 / Sigen CommMod (4G/3G/2G)	
Standard Compliance								
Standard ¹	IEC / EN 62109-1, IEC / EN 62109-2, IEC / EN 61000-6-1, IEC / EN 61000-6-2							

1. For all standards refer to the certificates category on the Sigenenergy website.

2. The information in this document reflects the current state of technology and is subject to change without notice. For the latest updates, please refer to the Sigenenergy website.

Sigen Hybrid Inverter

50.0 / 60.0 / 80.0 / 100.0 / 110.0 / 125.0 kW

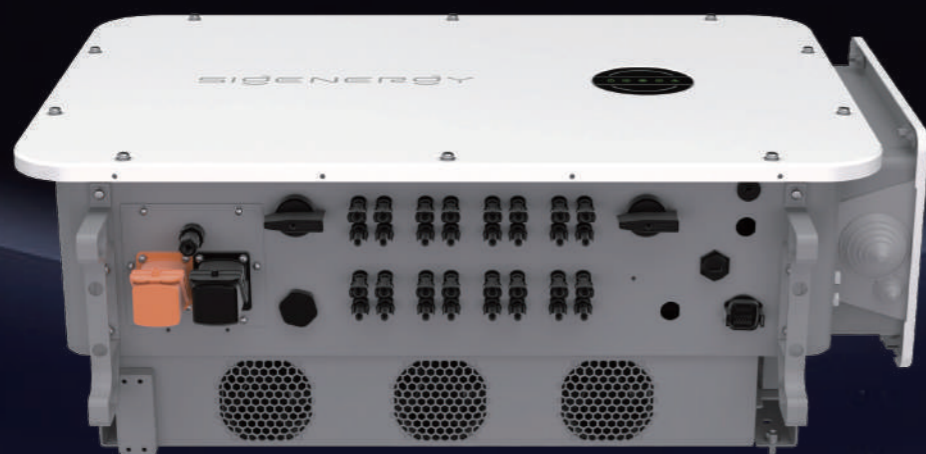

- Battery ready, easy upgrades to a PV + BESS at any time
- Smaller and lighter, easier installation and transportation
- Built-in EMS, supports 100 units in parallel without data logger
- Industry-leading 500m AFCI, top-tier safety across applications
- On-site self-power supply, removes the need for temporary power
- IP66 protection rating, ensuring worry-free outdoor deployment

Sigen Hybrid Inverter 50.0 / 60.0 / 80.0 / 100.0 / 110.0 / 125.0 kW

Sigen PV	50M1-HYA	60M1-HYA	80M1-HYA	100M1-HYA	110M1-HYA	125M1-HYA	Units	
DC Input (PV)								
Max. PV input power	100,000	120,000	160,000	200,000	220,000	220,000	Wp	
Max. DC input voltage	1,100						V	
Nominal DC input voltage	600 @380/400 Vac, 720 @480 Vac						V	
Start-up voltage	180						V	
MPPT voltage range	160 ~ 1,000						V	
Number of MPP trackers	4	5	6	8	8	8		
Number of PV strings per MPPT	2							
Max. input current per MPPT	40						A	
Max. short-circuit current per MPPT	60						A	
DC Input (Battery)								
Battery module models	SigenStack BAT 12.0							
System configuration quantity range ¹	4 ~ 21						pcs	
Max. charge power	55,000	66,000	88,000	110,000	121,000	137,500	W	
Max. discharge power	55,000	66,000	88,000	110,000	121,000	137,500	W	
Max. operating current	180						A	
AC Output								
Nominal output active power	50,000	60,000	80,000	100,000	110,000	125,000	W	
Max. output apparent power	55,000	66,000	88,000	110,000	121,000	137,500	VA	
Max. output active power (cosΦ=1)	55,000	66,000	88,000	110,000	121,000	137,500	W	
Nominal output current @380Vac	76.0	91.2	121.5	151.9	167.1	189.9	A	
Nominal output current @400Vac	72.5	87.0	115.9	144.9	159.4	181.2	A	
Nominal output current @480Vac	60.2	72.2	96.3	120.3	132.4	150.4	A	
Max. output current @380/400Vac	83.6	100.3	133.7	167.1	183.8	208.9	A	
Max. output current @480Vac	66.2	79.4	105.9	132.4	145.6	165.5	A	
Nominal output voltage	380 / 400 / 480, 3W+(N)+PE						Vac	
Nominal grid frequency	50 / 60						Hz	
Power factor	0.8 leading ~ 0.8 lagging							
Total current harmonic distortion	THDi < 3%	THDi < 3%	THDi < 2%	THDi < 2%	THDi < 2%	THDi < 2%		
Efficiency								
Max. efficiency @380/400 Vac	98.6%							
European efficiency @380/400 Vac	98.3%	98.3%	98.3%	98.4%	98.4%	98.3%		
Max. efficiency @480 Vac	98.8%							
European efficiency @480 Vac	98.4%	98.4%	98.4%	98.6%	98.6%	98.4%		
Protection								
Safety protection feature	DC reverse polarity protection, Insulation monitoring, Residual current monitoring, Arc fault circuit interrupter, AC overcurrent/overvoltage/short-circuit protection, Type II DC/AC surge protection, Anti-islanding protection							
General Data								
Dimensions (W / H / D)	918 / 640 / 340				999 / 668 / 340			mm
Weight	72	75	75	78	78	95	kg	
Nighttime power consumption	< 3.5						W	
Storage temperature range	-40 ~ 70						°C	
Operating temperature range	-30 ~ 60						°C	
Relative humidity range	0% ~ 100%							
Max. operating altitude	5,000 (Derating at 4,000m)						m	
PV connection type	MC4 (Max. 6 mm ²)							
AC connection type	OT / DT terminal (Max. 240 mm ²)							
Cooling	Smart air cooling							
Ingress protection rating	IP66							
Communication	WLAN / Fast Ethernet / RS485 / Sigen CommMod (4G/3G/2G)							
Standard Compliance								
Standard ²	IEC / EN 62109-1, IEC / EN 62109-2, IEC / EN 61000-6-1, IEC / EN 61000-6-2							

1. The requirements for the PV string open-circuit voltage in a PV+ESS DC coupling system are as follows: 1) When the system is configured with ≥19 battery modules, the string open-circuit voltage should meet the following minimum requirements: 1.1) If configured with 21 battery modules, the string open-circuit voltage should be > 935 V; 1.2) If configured with 20 battery modules, the string open-circuit voltage should be > 870 V; 1.3) If configured with 19 battery modules, the string open-circuit voltage should be > 805 V. 2) When the system is configured with 4 to 18 battery modules, the string open-circuit voltage has no special requirements.

2. For all standards refer to the certificates category on the Sigenenergy website.

3. The information in this document reflects the current state of technology and is subject to change without notice. For the latest updates, please refer to the Sigenenergy website.

Sigen Hybrid Inverter

50.0 / 60.0 / 80.0 / 100.0 / 110.0 kW



- Seamless switchover, ensuring 0ms load-side disruption operation
- 150% overload for 10s, handling impact loads for smooth device startup
- Minimal size & weight in the same power range, ensures simple installation
- Multi-unit connection via Energy Gateway, flexible expansion from kW to MW
- DC coupling micro-grid solution, simplifies configuration & boosts efficiency

Sigen Hybrid Inverter 50.0 / 60.0 / 80.0 / 100.0 / 110.0 kW

Preliminary

Sigen PV	50M1-HYB	60M1-HYB	80M1-HYB	100M1-HYB	110M1-HYB	Units
DC Input (PV)						
Max. PV input power	100,000	120,000	160,000	200,000	220,000	Wp
Max. DC input voltage						V
Nominal DC input voltage	600 @380/400 Vac, 720 @480 Vac					V
Start-up voltage	180					V
MPPT voltage range	160 - 1,000					V
Number of MPPT trackers	4	5	6	8	8	
Number of PV strings per MPPT	2					
Max. input current per MPPT	40					A
Max. short-circuit current per MPPT	60					A
DC Input (Battery)						
Battery module models	SigenStack BAT 12.0					
Battery controller models	SigenStack BC M2-0.5C-BST / SigenStack BC M2-1C-BST					
System configuration quantity range ¹	4 - 21					pcs
Max. charge power	55,000	66,000	88,000	110,000	121,000	W
Max. discharge power	55,000	66,000	88,000	110,000	121,000	W
Max. operating current	180					A
AC Output (On-grid)						
Nominal output active power	50,000	60,000	80,000	100,000	110,000	W
Max. output apparent power	55,000	66,000	88,000	110,000	121,000	VA
Max. output active power (cosΦ=1)	55,000	66,000	88,000	110,000	121,000	W
Nominal output current @380Vac	76.0	91.2	121.5	151.9	167.1	A
Nominal output current @400Vac	72.5	87.0	115.9	144.9	159.4	A
Nominal output current @480Vac	60.2	72.2	96.3	120.3	132.4	A
Max. output current @380/400Vac	83.6	100.3	133.7	167.1	183.8	A
Max. output current @480Vac	66.2	79.4	105.9	132.4	145.6	A
Nominal output voltage	380 / 400 / 480, 3W+N+PE					Vac
Nominal grid frequency	50 / 60					Hz
Power factor	0.8 leading ~ 0.8 lagging					
Total current harmonic distortion	THDi < 3%					
AC Input (On-grid)						
Max. input apparent power	100,000	120,000	160,000	160,000	160,000	VA
Max. input current @380/400Vac	151.9	182.3	243.1	243.1	243.1	A
Max. input current @480Vac	120.3	144.4	192.5	192.5	192.5	A
Max. continuous AC passthrough (grid to load)	83.6	100.3	133.7	167.1	183.8	A
AC Output (Backup)						
Nominal output active power	50,000	60,000	80,000	100,000	110,000	W
Max. output apparent power	55,000	66,000	88,000	110,000	121,000	VA
Peak output power (10 seconds)	75,000	90,000	120,000	150,000	150,000	W
Nominal output voltage	380 / 400 / 480, 3W+N+PE					V
Nominal output frequency	50 / 60					Hz
Power factor	0.8 leading ~ 0.8 lagging					
Total voltage harmonic distortion	THDv < 3%					
Disruption time of backup switch ²	0					ms
Efficiency						
Max. efficiency @380/400 Vac	98.3%					
European efficiency @380/400 Vac	97.9%	97.9%	98.0%	98.0%	98.0%	
Max. efficiency @480 Vac	98.5%					
European efficiency @480 Vac	98.2%	98.2%	98.3%	98.3%	98.3%	
Protection						
Safety protection feature	DC reverse polarity protection, Insulation monitoring, Residual current monitoring, Arc fault circuit interrupter, AC overcurrent/overvoltage/short-circuit protection, Type II DC/AC surge protection, Anti-islanding protection					
General Data						
Dimensions (W / H / D)	1097 / 668 / 340					mm
Weight	99	102	102	105	105	kg
Storage temperature range	-40 ~ 70					°C
Operating temperature range	-30 ~ 60					°C
Relative humidity range	0% ~ 100%					
Max. operating altitude	5,000 (Derating at 4,000m)					m
Cooling	Smart air cooling					
Ingress protection rating	IP66					
Communication	WLAN / Fast Ethernet / RS485 / Sigen CommMod (4G/3G/2G)					
Standard Compliance						
Standard ³	IEC / EN 62109-1, IEC / EN 62109-2, IEC / EN 61000-6-1, IEC / EN 61000-6-2					

1. The requirements for the PV string open-circuit voltage in a PV+ESS DC coupling system are as follows: 1) When the system is configured with ≥19 battery modules, the string open-circuit voltage should meet the following minimum requirements: 1.1) If configured with 21 battery modules, the string open-circuit voltage should be > 935 V; 1.2) If configured with 20 battery modules, the string open-circuit voltage should be > 870 V; 1.3) If configured with 19 battery modules, the string open-circuit voltage should be > 805 V. 2) When the system is configured with 4 to 18 battery modules, the string open-circuit voltage has no special requirements.

2. This refers to the load-side disruption time. Test conditions: In the open-circuit state of the power grid, the total power of the Sigen Hybrid Inverter is higher than the total power of the loads.

3. For all standards refer to the certificates category on the Sigenenergy website.

4. For Sigen energy gateway connections, the inverter should be connected to the gateway via its AC output port (Grid).

5. The information in this document reflects the current state of technology and is subject to change without notice. For the latest updates, please refer to the Sigenenergy website.

SigenStack

Innovative modular energy storage system



- Pack-level safety protection, precise thermal runaway control
- Higher energy density saves space and eases site selection
- IP66-rated design eliminates regular and complex O&M
- Pack-level active balancing, no need for on-site SOC calibration
- Modular design, stackable installation & ultra-fast commissioning

C&I Energy Storage System

SigenStack BC	M2-0.5C ¹	M2-0.5C-BST	M2-1C-BST	Units
Max. output current (to inverter)		180		A
Max. input current (from inverter)		180		A
Operating voltage range		550 ~ 1,100		V
Nominal charge/discharge current of battery	157	157	314	A
Weight	50	60	60	kg
Dimensions (W / H / D)		770 / 248 / 363		mm
Communication		CAN		
Compatible inverter	Sigen C&I Hybrid Inverter Series			

	SigenStack BAT 12.0	Units
Performance Specification		
Battery type	LiFePO ₄	
Cell capacity	314	Ah
Cycle life ²	10,000	
Total energy capacity per module	12.06	kWh
Weight	105	kg
Dimensions (W / H / D)	770 / 300 / 363	mm
Nominal charge / discharge rate	0.5C	
Max. charge / discharge rate	1C	
System configuration quantity range	4 ~ 21	pcs
Max. system energy capacity	253	kWh

System General Data		
Max. number of modules per stack	7	pcs
Max. number of modules per system	21	pcs
Fire suppression system	Aerosol, smoke sensor and exhausting system	
Dimensions of base (W / H / D)	770 / 195 / 363	mm
Storage temperature range	-25 ~ 60	°C
Operating temperature range	-20 ~ 55	°C
Relative humidity range	0% ~ 100%	
Max. operating altitude	4,000 (Derating at 2,000m)	m
Cooling	Smart air cooling	
System ingress protection rating	IP66	
Installation method	Floor standing	
Noise ³	< 65	dB

Standard Compliance		
Standard ⁴	IEC/EN 60730-1, UN 38.3, IEC/EN 62619, IEC/EN 63056, IEC/EN 62040, UL9540A	

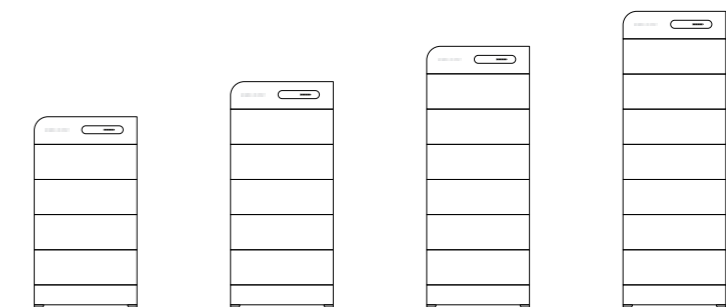

	4	5	6	7	Units
Number of battery modules					pcs
Total energy capacity	48.24	60.3	72.36	84.42	kWh
Total weight	500	605	710	815	kg
Total height (with base and SigenStack BC)	1,643	1,943	2,243	2,543	mm
Total width			770		mm
Total depth			363		mm

1. SigenStack BC M2-0.5C can only be used in applications where an on-grid energy storage system with ≥ 20 battery modules operates under 380/400V grid voltage. For other scenarios, please utilize the battery controller with 'BST' model.
2. This is provided by the battery cell manufacturer. Based on cell test condition of 25±2°C, 0.5C charge and discharge rate and SOH=60%.
3. Noise level is tested based on the rated operating conditions (25 °C ambient temperature, 0.5C charge/discharge rate, 400Vac output voltage).
4. For all standards refer to the certificates category on the Sigenenergy website.
5. This document reflects current technology and is subject to change without notice. Refer to the Sigenenergy website for the latest information.

Sigen Energy Controller

5.0 – 30.0 kW Three Phase

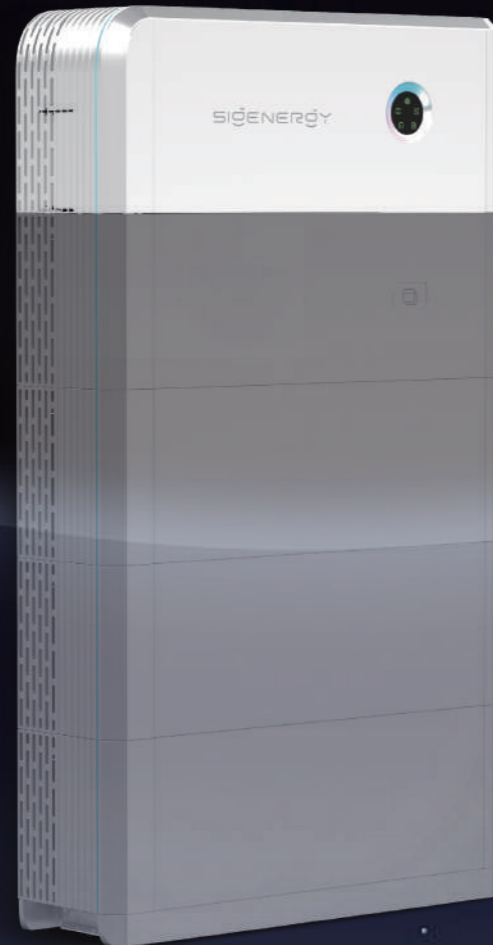

- EMS-integrated intelligent management for precision control
- Max. 1.6 DC/AC ratio compatibility, higher energy utilization
- Unbalanced 3-phase power output, ensuring efficient operation
- 150% peak output power in off-grid mode, instant high-power boost
- Up to 4 MPP trackers for maximum solar energy extraction

Sigen Energy Controller 5.0–30.0 kW Three Phase ¹

SigenStor EC	5.0 TP	6.0 TP	8.0 TP	10.0 TP	12.0 TP	15.0 TP	17.0 TP	20.0 TP	25.0 TP	30.0 TP	Units	
DC Input (PV)												
Max. PV power	8,000	9,600	12,800	16,000	19,200	24,000	27,200	32,000	40,000	48,000	W	
Max. DC input voltage ²							1,100					V
Nominal DC input voltage							600					V
Start-up voltage							180					V
MPPT voltage range							160 ~ 1,000					V
Number of MPP trackers	2			3			4					
Number of PV strings per MPPT							1					
Max. input current per MPPT							16					A
Max. short-circuit current per MPPT							20					A
AC Output (On-grid)												
Nominal output power	5,000	6,000	8,000	10,000	12,000	15,000	17,000	20,000	25,000	30,000	W	
Max. output apparent power	5,500	6,600	8,800	11,000	13,200	16,500	18,700	22,000	27,500	33,000	VA	
Nominal output current	7.6	9.1	12.2	15.2	18.2	22.8	25.8	30.4	38.0	45.5	A	
Max. output current	8.4	10.0	13.4	16.7	20.1	25.1	28.4	33.4	41.8	50.0	A	
Nominal output voltage							380 / 400, 3W+N+PE					V
Nominal grid frequency							50 / 60					Hz
Power factor							0.8 leading ~ 0.8 lagging					
Total current harmonic distortion							THDi < 2%					
Efficiency												
Max. efficiency	98.1%	98.2%	98.3%	98.3%	98.3%	98.3%	98.3%	98.3%	98.3%	98.4%		
European efficiency	96.1%	96.6%	97.1%	97.5%	97.7%	97.9%	97.9%	97.9%	98.0%	98.0%		
AC Output (Backup)												
Peak output power (10 seconds)	7,500	9,000	12,000	15,000	18,000	22,500	25,500	30,000	30,000	36,000	W	
Nominal output voltage							380 / 400, 3W+N+PE					V
Nominal output frequency							50 / 60					Hz
Power factor							0.8 leading ~ 0.8 lagging					
Total voltage harmonic distortion							THDv < 2%					
Disruption time of backup switch ³							0					ms
Battery Connection												
Battery module models							SigenStor BAT series					
Number of modules per controller							1 ~ 6					pcs
Battery module voltage range							600 ~ 900					V
Protection												
Safety protection feature	DC reverse polarity protection, Insulation monitoring, Residual current monitoring, Arc fault circuit interrupter ⁴ , AC overcurrent/overvoltage/short-circuit protection. Type II DC/AC surge protection, Anti-islanding protection											
General Data												
Dimensions (W / H / D)							700 / 300 / 260					mm
Weight							36					kg
Storage temperature range							-40 ~ 70					°C
Operating temperature range							-30 ~ 60					°C
Relative humidity range							0% ~ 100%					
Max. operating altitude							4,000					m
Cooling							Smart air cooling					
System ingress protection rating							IP66					
Communication							WLAN / Fast Ethernet / RS485 / Sigen CommMod (4G/3G/2G)					
Standard Compliance												
Standard ⁵	IEC/EN 62109-1, IEC/EN 62109-2, IEC/EN 61000-6-1, IEC/EN 61000-6-2											

1. Sigen Energy Controller 30.0 kW Three Phase is only available in specific regions. Please contact Sigenenergy or local distributors for details.
2. The inverter will initiate protection if the input voltage exceeds the MPPT operating voltage range.
3. This refers to the load-side disruption time, to achieve this functionality Sigen Energy Controller needs to be used together with Sigen Battery and Sigen Energy Gateway. Test conditions: In the open-circuit state of the power grid, the nominal power of the Sigen Energy Controller is higher than the total power of the backup loads.
4. This is an optional feature only supported in certain models, please contact Sigenenergy for more information.
5. For all standards refer to the certificates category on the Sigenenergy website.

Sigen Battery

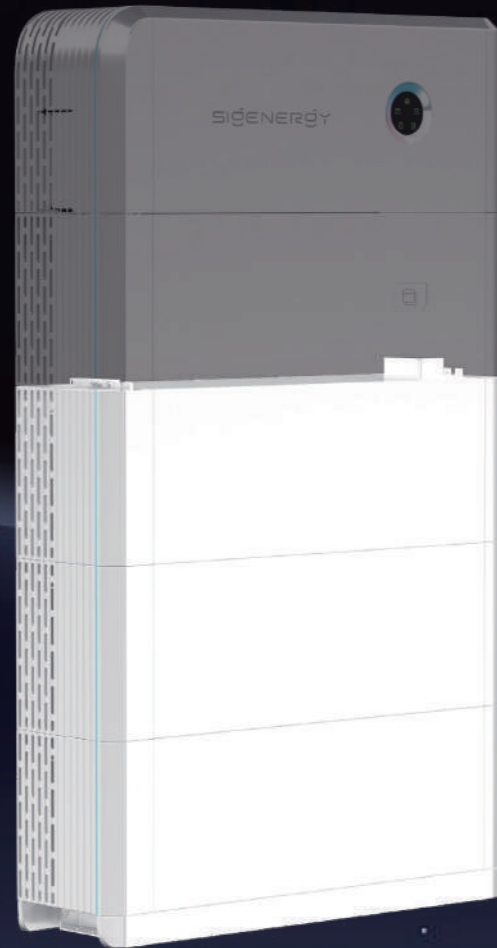

- Premium 314Ah cells with 10,000 cycles, long-lasting & reliable
- 5-layer battery safety protection to define the safety standard
- Battery optimizer inside, mix old and new, upgrade with ease
- Higher energy density, efficient storage, compact design
- 100% depth of discharge, maximum energy utilization

Sigen Battery 6.0 / 10.0

SigenStor BAT	6.0	10.0	Units
Performance Specification			
Battery type	LiFePO ₄		
Cell capacity	314		Ah
Cycle life ¹	10,000		
Total energy capacity	6.02	9.04	kWh
Usable energy capacity ²	5.84	8.76	kWh
Depth of discharge ³	100%		
Max. charge / discharge power	3,000	4,600	W
Peak charge / discharge power (10 seconds)	4,500	6,900	W
General Data			
Weight	62	78	kg
Dimensions (W / H / D)	767 / 270 / 265		mm
Storage temperature range	-25 ~ 60		°C
Operating temperature range	-20 ~ 55		°C
Relative humidity range	5% ~ 95%		
Max. operating altitude	4,000		m
Cooling	Natural convection		
System ingress protection rating	IP66		
Installation method	Floor standing / Wall-mounted		
Standard Compliance			
Standard ⁴	IEC/EN 60730-1, UN 38.3, IEC/EN 62619, IEC/EN 63056, IEC/EN 62477		

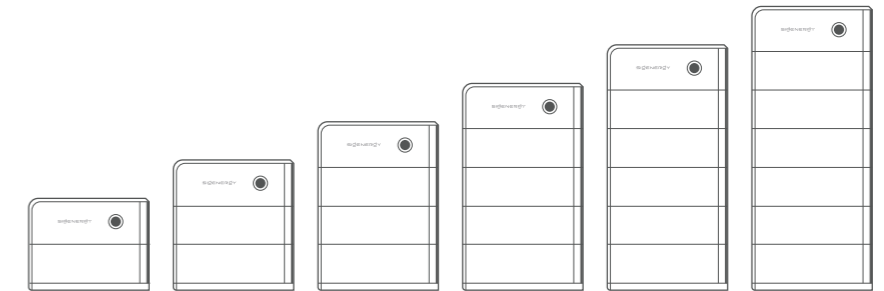

Number of battery modules ⁵	1	2	3	4	5	6	pcs
Total energy capacity	9.04	18.08	27.12	36.16	45.2	54.24	kWh
Max. charge / discharge power	4.6	9.2	13.8	18.4	23	27.6	kW
Total weight	120	199	279	357	436	515	kg
Total height (with base)	640	910	1,180	1,450	1,720	1,990	mm
Total width (with decorative covers)	850						mm
Total depth (with decorative covers)	265						mm

1. This is provided by the battery cell manufacturer. Based on cell test condition of 25±2°C, 0.5C charge and discharge rate and SOH=60%.
2. Test conditions: 100% depth of discharge, 0.2C rate charge & discharge averagely at 25°C, at the beginning of life.
3. Refers to usable capacity. Battery must be recharged within 7 days after being fully discharged to keep battery healthy.
4. For all standards refer to the certificates category on the Sigenenergy website.
5. The data in the table is based on the combination of SigenStor BAT 10.0 and SigenStor EC three-phase as an example, with a ground-mounted installation.

Sigen EV DC Charging Module



Experience Fast DC charging

- World's first V2X-integrated all-in-one home energy system
- 25kW bi-directional charging, rapid replenishment for EVs
- 150V-1000V charging voltage, universal EV compatibility
- IP66 protection rating, maintenance-free, always reliable
- Support 100% green charging, drive with sun power



Sigen EV DC Charging Module

SigenStor EVDC ¹	12	25	Units
DC Charging			
Max. charging power of charging port	12.5	25	kW
Max. discharging power of charging port	12.5	25	kW
Operation voltage range	150 ~ 1,000		V
Max. operation current	40	80	A
Charging interfaces	CCS2		
Protection			
Short-circuit protection	Supported		
Over / Under voltage protection	Supported		
Overload protection	Supported		
Over temperature protection	Supported		
Reverse polarity protection	Supported		
Welded contactor check	Supported		
General Data			
Dimensions (W / H / D)	700 / 270 / 260		mm
Weight ²	39 (with 7.5m cable) / 41 (with 10m cable)		kg
Storage temperature range	-40 ~ 70		°C
Operating temperature range	-30 ~ 60		°C
Relative humidity range	5% ~ 95%		
Max. operating altitude	4,000		m
Cooling	Smart air cooling		
System ingress protection rating	IP66		
Integrated charging cable length ³	7.5 / 10		m
Function			
Authentication	RFID card / App / No authentication		
	Scheduled Charging	The system supports setting the charging start times	
	PV Surplus Charging	The system uses PV Surplus to charge EVs, enabling 100% green power. It also supports Battery Boost Charging with cut-off SOC setting, as well as Grid Charging. Moreover, it has the function of prioritizing Surplus PV power.	
	Fast Charging	The system draws power from the grid and PV simultaneously for the fastest charging speed and also supports additional Battery Boost Charging.	
Application	Bi-directional V2X operation ⁴ , Smart load management		
User interfaces	LED indicator, App, RFID		
Remote function	OTA, Remote diagnosis		
OCPP protocol	OCPP 1.6J ED 2		
Standard Compliance			
Standard ⁵	EN IEC 61851-1, EN 61851-23, EN IEC 61851-21-2, ETSI EN 303 645		

1. Sigen EV DC Charging Module needs to be used together with Sigen Energy Controller.

2. The net weight includes the CCS2 cable-assembly also, but excludes the exteriors, wall-mounting fixtures and the related attachments.

3. Integrated charging cable length refers to the length of the cable that extends from the Sigen EV DC Charging Module, not the length of the exposed cable.

4. V2X functionality is limited by the EV's capabilities. Once the relevant standards are published and tested, V2X feature can be upgraded through the OTA. For the official support of vehicle models and support timelines, please refer to future announcement made on the official website.

5. For all standards refer to the certificates category on the Sigenenergy website.

Sigen Energy Gateway



- Multiple Sigen C&I inverters connections supported for micro-grid system
- Seamless switchover, ensuring 0ms load-side disruption
- Built-in bypass circuit for enhanced system reliability
- Supports diesel generator connection & smart control
- Real-time current monitoring with 100ms zero export

Sigen Energy Gateway for Sigen C&I Inverter

Preliminary

Sigen Gateway	C600-B	C1200-B	Units
Grid Connection			
Grid connection type	Three phase		
Nominal AC voltage	380 ~ 400		V
Nominal AC current	912	1,824	A
Nominal AC power	600	1,200	kW
Nominal AC frequency	50 / 60		Hz
Disruption time of backup switch ¹	0		ms
AC Output to Backup Port			
Nominal AC voltage	380 ~ 400		V
Nominal AC current	1,824		A
Nominal AC power	1,200		kW
Nominal AC frequency	50 / 60		Hz
Overvoltage category	III		
Inverter Connection			
Number of connection ports	10	20	
Nominal AC voltage	380 ~ 400		V
Max. AC input current ²	200 (6 ports), 160 (4 ports)	200 (12 ports), 160 (8 ports)	A
Max. AC power ²	125 (6 ports), 80 (4 ports)	125 (12 ports), 80 (8 ports)	kW
Smart Port Connection			
Generator output voltage	380 ~ 400		V
Nominal AC current	1,824		A
Nominal AC power	1,200		kW
Generator 2-wire start	Supported		
General Data			
Dimensions (W / H / D)	1,800 / 2,300 / 1,270		mm
Weight	1,100	1,300	kg
Storage temperature range	-40 ~ 70		°C
Operating temperature range ³	-30 ~ 55		°C
Relative humidity range	0% ~ 95%		
Max. operation altitude ³	4,000		m
Cooling	Smart air cooling		
Ingress protection rating	IP20		
Communication	Fast Ethernet, RS485, dry contact		
Installation method	Ground-mounted		

1. This refers to the load-side disruption time, to achieve this functionality Sigen Energy Gateway needs to be used together with Sigen Hybrid Inverter and Sigen Battery. Test conditions: In the open-circuit state of the power grid, the total power of the Sigen Hybrid Inverter is higher than the total power of the backup loads.
2. This series of energy gateway has two types of molded case circuit breakers inside, please refer to the installation guide for their specific mounting locations.
3. Please consult Sigenergy for detailed power derating information.

Sigen Energy Gateway

Modular design for flexible and precise deployment



- Multiple Sigen C&I inverters connections supported for micro-grid system
- Modular cabinet, effortless side-by-side installation
- Seamless switchover, ensuring 0ms load-side disruption
- Built-in bypass circuit for enhanced system reliability
- Supports diesel generator connection & smart control
- Real-time current monitoring with 100ms zero export

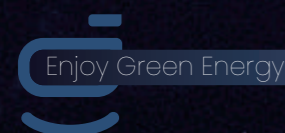

Sigen Energy Gateway for Sigen C&I Inverter

Preliminary

Energy Gateway Grid Switch Cabinet ¹

Sigen Gateway	C1600-B-GS	C2000-B-GS	C2400-B-GS	Units
Grid connection type	Three phase			
Nominal AC voltage	380 ~ 400			V
Nominal AC current	2,432	3,039	3,647	A
Nominal AC power	1,600	2,000	2,400	kW
Nominal AC frequency	50 / 60			Hz
Disruption time of backup switch ²	0			ms
Dimensions (W / H / D)	800 / 2,200 / 1,000			mm
Weight	600	660	680	kg

Energy Gateway Backup Load Cabinet

Sigen Gateway	C1600-B-BL	C2000-B-BL	C2400-B-BL	Units
Nominal AC voltage	380 ~ 400			V
Nominal AC current	2,432	3,039	3,647	A
Nominal AC power	1,600	2,000	2,400	kW
Nominal AC frequency	50 / 60			Hz
Overvoltage category	III			
Dimensions (W / H / D)	800 / 2,200 / 1,000			mm
Weight	600	660	680	kg

Energy Gateway Smart Load Cabinet (Optional)

Sigen Gateway	C1600-B-ST	C2000-B-ST	C2400-B-ST	Units
Generator output voltage	380 ~ 400			V
Nominal AC current	2,432	3,039	3,647	A
Nominal AC power	1,600	2,000	2,400	kW
Generator 2-wire start	Supported			
Dimensions (W / H / D)	800 / 2,200 / 1,000			mm
Weight	600	660	680	kg

Energy Gateway Inverter Cabinet

Sigen Gateway	B-INV-15 ³	B-INV-24 ³	Units
Number of connection ports	15	24	
Nominal AC voltage	380 ~ 400		V
Max. AC input current per connection	200	160	A
Max. AC input power per connection	125	80	kW
Dimensions (W / H / D)	800 / 2,200 / 1,000		mm
Weight	600	660	kg

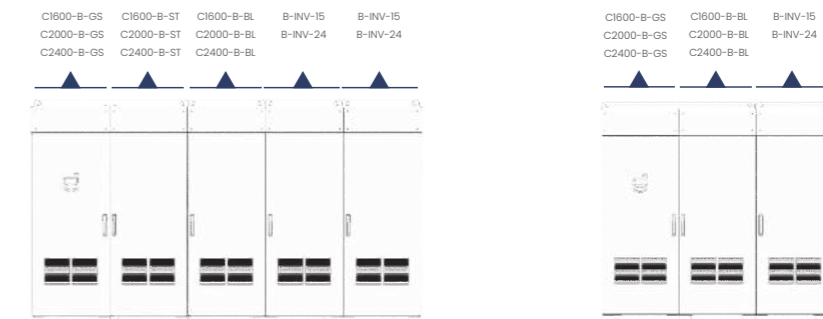

System General Data

Storage temperature range	-40 ~ 70	°C
Operating temperature range ⁴	-30 ~ 55	°C
Relative humidity range	0% ~ 95%	
Max. operation altitude ⁴	4,000	m
Cooling	Smart air cooling	
Ingress protection rating	IP20	
Communication	Fast Ethernet, RS485, dry contact	
Installation method	Ground-mounted	

- Grid switch cabinets (C1600-B-GS/C2000-B-GS/C2400-B-GS), backup load cabinets (C1600-B-BL/C2000-B-BL/C2400-B-BL) and smart load cabinets (C1600-B-ST/C2000-B-ST/C2400-B-ST) must be matched exclusively within their respective series. Cross-series combinations are not compatible.
- This refers to the load-side disruption time, to achieve this functionality Sigen Energy Gateway needs to be used together with Sigen Hybrid Inverter and Sigen Battery. Test conditions: In the open-circuit state of the power grid, the total power of the Sigen Hybrid Inverter is higher than the total power of the backup loads.
- Sigen Gateway B-INV-15 supports the connection of 15 inverters. Sigen Gateway B-INV-24 supports the connection of 24 inverters. The two types of cabinets can be deployed in combination to expand inverter connection capacity. Please consult Sigenenergy for detailed power derating information.
- In accordance with IEC 60364-4-43, if the existing load-side distribution cabinet is already fitted with overload protection device and is installed within 3 m of Sigen Energy Gateway, a backup load cabinet is not required, and a combiner panel cabinet (Sigen Gateway B-CP) can be selected.
- If the inverter connection ports of inverter cabinets are insufficient, expansion and customization via a combiner panel cabinet (Sigen Gateway B-CP) are available. Please consult Sigenenergy for details.

Sigen Energy Gateway



- Multiple SigenStor connections supported for micro-grid system
- Seamless switchover, ensuring 0ms load-side disruption
- Built-in bypass circuit for enhanced system reliability
- Supports diesel generator connection & smart control
- Real-time current monitoring with 100ms zero export

Sigen Energy Gateway for SigenStor

Sigen Gateway	C60-2	C120-6	C180-9	C300-12	C600	C1200	Units
Grid Connection							
Grid connection type	Three phase						
Nominal AC voltage	380 ~ 400						
Nominal AC current	91.2	182.4	274	456	912	1,824	A
Nominal AC power	60	120	180	300	600	1,200	kW
Nominal AC frequency	50 / 60						
Disruption time of backup switch ¹	0						
AC Output to Backup Port							
Nominal AC voltage	380 ~ 400						
Nominal AC current	91.2	182.4	274	456	912	1,824	A
Nominal AC power	60	120	180	300	600	1,200	kW
Nominal AC frequency	50 / 60						
Overvoltage category	III						
Inverter Connection							
Number of connection ports	2	6	9	12	30	50	
Nominal AC voltage	380 ~ 400						
Nominal AC current	45.6						
Smart Port Connection							
Generator output voltage	380 ~ 400						
Nominal AC current	91.2	182.4	274	456	912	1,824	A
Nominal AC power	60	120	180	300	600	1,200	kW
Generator 2-wire start	Supported						
General Data							
Dimensions (W / H / D)	510 / 795 / 173	850 / 1,152 / 305	800 / 2,300 / 830	1,800 / 2,300 / 1,270		mm	
Weight	35	74	350	400	1,100	1,300	kg
Storage temperature range	-40 ~ 70						
Operating temperature range ²	-30 ~ 55						
Relative humidity range	0% ~ 100%		0% ~ 95%		0% ~ 95%		
Max. operation altitude ²	4,000						
Cooling	Natural convection		Natural convection		Smart air cooling		
Ingress protection rating	IP55		IP20		IP20		
Communication	Fast Ethernet , RS485, dry contact						
Installation method	Wall-mounted		Ground-mounted		Ground-mounted		

1. This refers to the load-side disruption time, to achieve this functionality Sigen Energy Gateway needs to be used together with Sigen Energy Controller and Sigen Battery. Test conditions: In the open-circuit state of the power grid, the total power of the Sigen Energy Controller is higher than the total power of the backup loads.

2. Please consult Sigenergy for detailed power derating information and customized requirements.

Sigen Communication Module



- IP66 protection rate, more reliable
- Plug & play, easy to use
- Support 2G / 3G / 4G communication

Sigen Communication Module

	Sigen CommMod ¹	Units
Connection interface	USB	
Installation type	Plug-and-play	
Display	LED indicators	
Dimensions (W / H / D)	52 / 112 / 33	mm
Weight	90	g
Ingress protection rating	IP66	
Power consumption (typical)	< 4	W
Supported SIM card	Micro-SIM (12mm x 15mm)	
Supported standards	LTE-FDD B1/3/7/8/20/28A LTE-TDD B38/40/41 WCDMA B1/8 GSM/EDGE B3/8	
Storage temperature range	-40 ~ 70	°C
Operating temperature range	-30 ~ 60	°C
Relative humidity range	0% ~ 95%	
Max. operating altitude	4,000	m
Controller / Inverter compatibility	Sigen Energy Controller series Sigen Hybrid Inverter series Sigen PV Inverter series	

1. To ensure stable data transmission, the mobile signal for 2G signal ≥ 4 bars, 3G/4G signal ≥ 3 bars.
2. This product is only available in specific regions. Please contact Sigenergy or local distributors for details.

Sigen Power Sensor



Sigen Sensor Sub1G Kit



Sigen Power Sensor

- WiFi halow remote communication functionality (with Sigen Sensor Sub1G Kit)
- Efficient and stable data transmission up to 200m (with Sigen Sensor Sub1G Kit)
- 1% high-accuracy power detection for precise control
- Compact 1P size, plug-in design for easy installation
- Integrate smoothly with Sigenergy devices, no need for setup
- 50 ms data refresh rate, instantaneous data feed

Sigen Power Sensor

Sigen Sensor ¹	TP-CT100 ²	TP-CT300 ²	TP-CT600 ²	TPX-CH	TP-CT5	Units	
Power Supply							
Grid connection type			3P3W/3P4W				
AC input voltage range		176 ~ 276 (L-N), 277 ~ 304 (L-L)		100 ~ 480	52 ~ 264 (L-N) 90 ~ 456 (L-L)	Vac	
Nominal AC frequency			50 / 60				Hz
Measurement Accuracy							
Voltage accuracy			0.5%				
Current accuracy			0.5%				
Power accuracy			1%				
Frequency accuracy		0.5%		0.2%			
Communication							
Interface			RS485				
Baud rate			9,600		bps		
Protocol			Modbus RTU				
General Data							
Dimensions (W / H / D)		19 / 94.5 / 68.5 or 18 / 100 / 65.5 ²		72 / 100 / 65.5	72 / 98 / 65.5	mm	
Weight		0.08		0.35	0.23	kg	
Storage temperature range			-40 ~ 70				°C
Operating temperature range			-25 ~ 55				°C
Relative humidity range			0% ~ 95%				
Ingress protection rating			IP20				
Installation method			DIN Rail 35 mm				
CT Accessory							
Number of CT		3		3		pcs	
Cable length of CT		1		6		m	
Inner diameter of CT ²		24 / 16		24 / 24		mm	
Weight of CT ²		0.2 / 0.43		1.06 / 0.77		kg	
Max. operating current of CT		100		300		A	
Standard Compliance							
Standard			EN 61010-1:2010, EN 61010-2-030:2010				

	Sigen Sensor Sub1G Kit	Units
Working mode	AP(master device), STA(slave device)	
Communication method	RS485 / wireless communication	
Protocol	IEEE 802.11ah	
Operating voltage	85 ~ 277	Vac
Power consumption	2	W
Operating temperature range	-25 ~ 55	°C
Dimensions (W / H / D)	18 / 118 / 66	mm
Wireless frequency	868	MHz
Wireless transmission distance ³	≤ 200	m
Installation method	DIN Rail 35 mm	

1. For more models refer to the Sigenergy website.
2. Sensors from two different manufacturers may be shipped interchangeably as they are functionally identical. Please refer to the actual products received for confirmation.
3. Lab tests have shown a maximum horizontal range of up to 200 metres in open spaces, with shorter communication distances when walls are in the way.

Sigen Cloud

A platform for device lifecycle management and business decision-making.



- Instantly grasp business trends with data visualization and interactive data modules
- Batch remote system parameter configuration and automatic command retry
- Enhanced system operation status monitoring with multi-layer real-time cell-level information
- Real-time system data updates every 10 seconds, offering clear energy insights at a glance
- Sigen AI smart energy assistant, always online to resolve your inquiries instantly

	Business Operation	Interactive BI Dashboard Installer Points Dashboard Points Redemption Mall	
		Efficient Maintenance	Alarm Management System Ownership Management Group Systems to Manage
			System Monitoring
			Device Monitoring
			After-sales Service
		Organization Management	Company Information Installer Company Hierarchical Management
		Value-Added Services	AI Smart Assistant Third-party VPP Integration Open Northbound Integration

Leading the Way in Intelligent Manufacturing

Located in the Lin-gang New Area, Shanghai, a hub of world-class enterprises with strong innovative strengths, the manufacturing center is equipped with state-of-the-art technology and innovative manufacturing processes that allow us to produce high-quality products with exceptional efficiency. It also features the latest manufacturing execution system software (MES) which streamlines our operations and enables real-time monitoring of the production process. Additionally, Sigenergy's core production base, the Nantong Smart Manufacturing Hub, is under construction. Once completed, the facility is expected to produce 300,000+ inverters and battery packs yearly, providing strong manufacturing support to meet growing global demand.



Global Cases

Unlocking the Potential of C&I Energy Systems



Winery

Spain

1.5 MW AC output | 3 MWh ESS capacity



Office

China

250 kW AC output | 448 kWh ESS capacity



Factory

Spain

200 kW AC output | 400 kWh ESS capacity



Factory

Sweden

140 kW AC output | 280 kWh ESS capacity



Poultry farm

Myanmar

150 kW AC output | 144 kWh ESS capacity



Factory

South Africa

2.4 MW AC output | 4.1 MWh ESS capacity

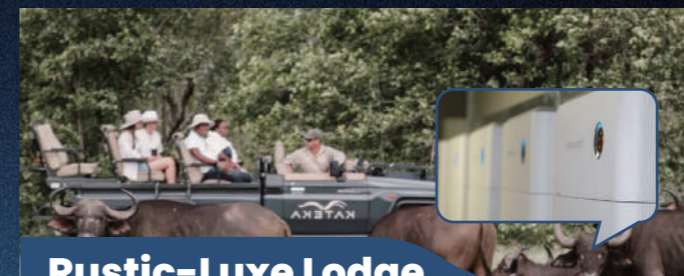

Rustic-Luxe Lodge

South Africa

125 kW AC output | 240 kWh ESS capacity



Hotel

Mauritius

50 kW AC output | 96 kWh ESS capacity



Community

Australia

70 kW AC output | 336 kWh ESS capacity



Game Ranch

Namibia

300 kW AC output | 960 kWh ESS capacity

Global Cases

Unlocking the Potential of C&I Energy Systems



Utility-scale
Bulgaria

10 MW AC output | 20 MWh ESS capacity



Factory
Belgium

440 kW AC output | 1013 kWh ESS capacity



Farm
Switzerland

100 kW AC output | 217 kWh ESS capacity



Fruit warehouse
Italy

100 kW AC output | 300 kWh ESS capacity



Office
Vietnam

1120 kWp PV capacity | 880 kW AC output



Factory
China

5.0 MWp PV capacity | 4.2 MW AC output



Machine Factory
South Africa

220 kW AC output | 168 kWh ESS capacity



Aquaculture farm
China

4.3 MW AC output | 6 MWh ESS capacity



Container yard
China

60 kW AC output | 240 kWh ESS capacity



Factory
Malaysia

1.2 MWp PV capacity | 0.88 MW AC output