

Sigen Hybrid (3.0–12.0) TP2 series Installation Guide

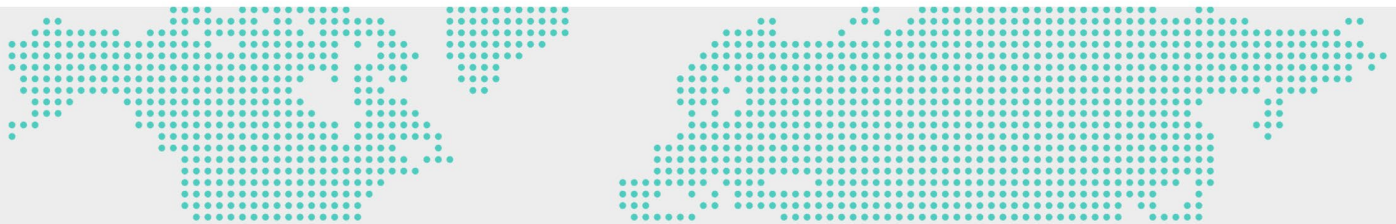

Version: 03
Release date: 2025-12-03



⚠ Caution

- Only trained or qualified persons with electrical engineering knowledge can work directly on the equipment.
- Operators should be familiar with national and local laws, regulations, and standards, and the compositions and operating principles of relevant systems.
- Before operations, please carefully read operating requirements and precautions in this document and Important Notice. Any equipment damage caused by improper operation will not be covered under warranty.

1 Introduction

1.1 Appearance and Dimensions

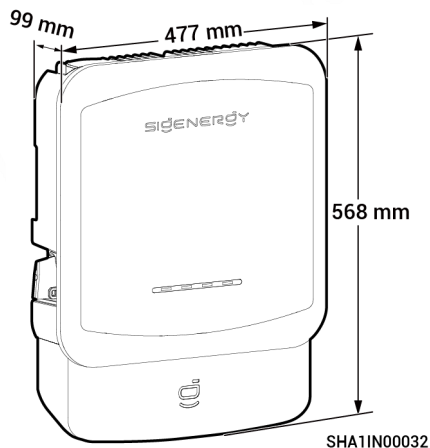

1.2 Port Introduction

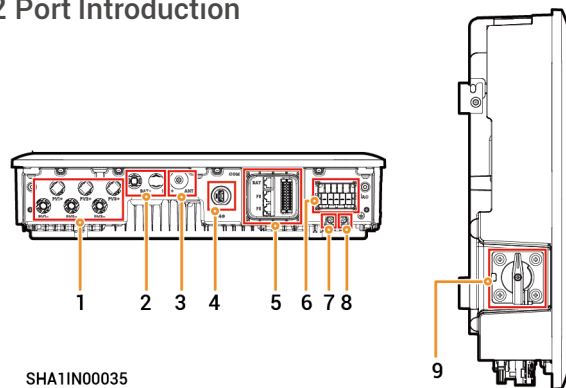

No.	Name	Marking
1	DC terminal block	PV1+/PV1- /PV2+/PV2- /PV3+/PV3-
2	Battery pack input interface	BAT+/BAT-
3	Antenna interface	ANT
4	CommMod interface	4G
5	Communication port	COM
6	AC terminal	AC
7	Grounding point (connected to the battery pack)	
8	Grounding point (connected to the protective ground cable)	
9	DC switch	DC SWITCH

2 Inspections Before Installation

- Check whether the components are entirely supplied against the packing list and whether the appearance is in good condition. For any problem, contact your sales representative.
- Parts and accessories supplied with the packing box are personal assets of the owner and must not be taken away from the installation site.
- Check and ensure the completeness of personal protective equipment and installation tools; replenish if necessary.
- Check and ensure the correctness of quantity and specifications of the installer-provided cables; re-prepare if necessary.

Personal Protective Equipment



Safety hat



Goggles



Dust mask



Protective gloves



Insulating gloves



Insulating shoes

Installation Tools

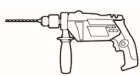

Power drill

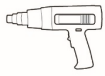

Heat gun

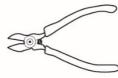

Wire cutter



Network cable pliers



Crimping pliers



Wire stripper



Scissors



Cable ties



Heat shrinkable sleeve



Insulated sleeve set



Torque socket wrench



Marker



Rubber mallet



Hexagonal L-type wrench (4 mm on the opposite side)

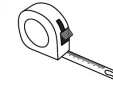

Tape measure

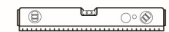

Level



Vacuum cleaner

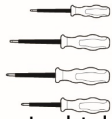

Insulated screwdriver set



Open-end wrench
(Model: H4TW0001
Supplier: Amphenol)



PV terminal crimping pliers
(Model: H4TC0003
Supplier: Amphenol)



Cold terminal crimping pliers

Installer-provided Cables

Caution

- The specifications of installer-provided cables shall conform to the regulations and standards on cables in the countries/regions where they are located.
- When the inverter is connected to other equipment, L1, L2, L3, N, and PE shall be connected in sequence, and cannot be mixed.
- Please prepare the cables according to actual needs.

No.	Cable Name	Recommended Specification
1	Protective ground cable	Single-core copper core flexible conductor for outdoor use <ul style="list-style-type: none"> • Cross-sectional area of 3 kW to 8 kW conductor: 4 mm² • Cross-sectional area of 10 kW to 12 kW conductor: 6 mm²
2	AC cable	Five-core copper core flexible cable for outdoor use (L1, L2, L3, N, PE) <ul style="list-style-type: none"> • Cross-sectional area of 3 kW to 8 kW conductor: 4 mm² • Cross-sectional area of 10 kW to 12 kW conductor: 6 mm² Cable OD: 13 mm to 21 mm
3	RS485 signal cable	Cross-sectional area of the conductor : 0.5 mm ² to 0.75 mm ² (multi-core flexible conductor, tubular terminals are required); 0.5 mm ² to 1 mm ² (single-strand hard wire, no tubular terminals are required) Cable OD: 5.5 mm to 6.5 mm Cable length: ≤ 1000 m Baud rate: ≤ 9600 bps
4	Inverter-to-router network cable	CAT6 eight-core shielded twisted pair for outdoor use Cross-sectional area of the conductor: 0.13 mm ² to 0.2 mm ² ; cable OD: 4.5 mm to 6.1 mm Single cable length: ≤ 100 m ^[1]
5	Inverter-to-battery pack network cable	CAT6 eight-core shielded twisted pair for outdoor use Cross-sectional area of the conductor: 0.2 mm ² ; cable OD: 4.5 mm to 6.1 mm Single cable length: ≤ 20 m
6	DC input cable of the inverter	Photovoltaic copper core cable for outdoor use Cross-sectional area of conductor: 4 mm ² to 6 mm ² , cable OD: 4.5 mm to 7.8 mm

Note [1]: The cable length should be limited for good communication. Too long cable degrades the communication effect.

3 Site Requirements

Tips

- Before installing the equipment, be sure to read the following installation requirements carefully. The company will not bear any responsibility if the equipment malfunctions, is damaged, or even causes a personal safety accident during operation due to failure to operate as required.
- During actual installation, the selection of installation location should comply with local firefighting, environmental protection regulations, and other relevant laws. The specific installation location planning should be subject to the installer or engineering, procurement, and construction (EPC) contracts.

Installation Environment

- Do not install the equipment in a smoky, flammable, or explosive environment.
- Avoid exposing the equipment to direct sunlight, rain, standing water, snow, or dust. Install the equipment in a sheltered place. Take preventive measures in operating areas prone to natural disasters such as floods, mudslides, earthquakes, and typhoons.
- Do not install the equipment in an environment with strong electromagnetic interference.
- The temperature and humidity of the installation environment should meet equipment requirements.
- The equipment shall be installed in an area at least 500 m away from corrosion sources such as high salt and high acidity (corrosion sources include but are not limited to seaside, thermal power plants, chemical plants, smelters, coal plants, rubber plants, electroplating plants, etc.)
- In areas with good marine environments (such as Norway, where the nearshore salinity is ≤ 28 psu), the mounting distance of the device from the coastline can be appropriately relaxed to > 200 m.
- If the outer surface of the device is damaged, please repaint the device in time.

Installation Location

- Do not tilt the equipment or place it upside down. Ensure that the equipment is horizontally installed.
- Do not install the equipment in areas easily accessible to children.
- Do not install the equipment in a place with fire hazards or is prone to moisturizing.
- The equipment produces sound when it is operating. Please install the equipment in a place with appropriate distance at which there is no impact to daily work and life.
- Do not install the equipment in a sealed, poorly ventilated location without fire protection measures and difficult access for firefighters.
- The equipment is hot when it is operating. If the equipment is installed indoors, please ensure good indoor ventilation. The indoor temperature shall not rise by 3°C due to the operation of the equipment. Otherwise, derating of the equipment will be caused.
- Do not install the equipment in mobile scenarios such as recreational vehicles, cruise ships, and trains.
- You are advised to install the equipment in a location where you can easily access, install, operate, maintain it, and view the indicator status.
- Keep the equipment clear of vehicle passage when installed in a garage to avoid collisions.

Installation Base

- Do not install the equipment on a flammable base.
- The installation base should meet the load-bearing requirement. Solid brick-concrete structures and concrete walls are recommended.
- The installation base should be flat, and the installation area should meet the installation space requirements.
- No plumbing or electrical alignments should be inside the installation base to avoid potential drilling hazards during equipment installation.

Tips

To ensure optimal performance of the device, it is suggested that the installation distance between the device and surrounding obstacles be planned with reference to the diagram. If the installation site is well-ventilated, the optimal solution may be deployed based on actual conditions.

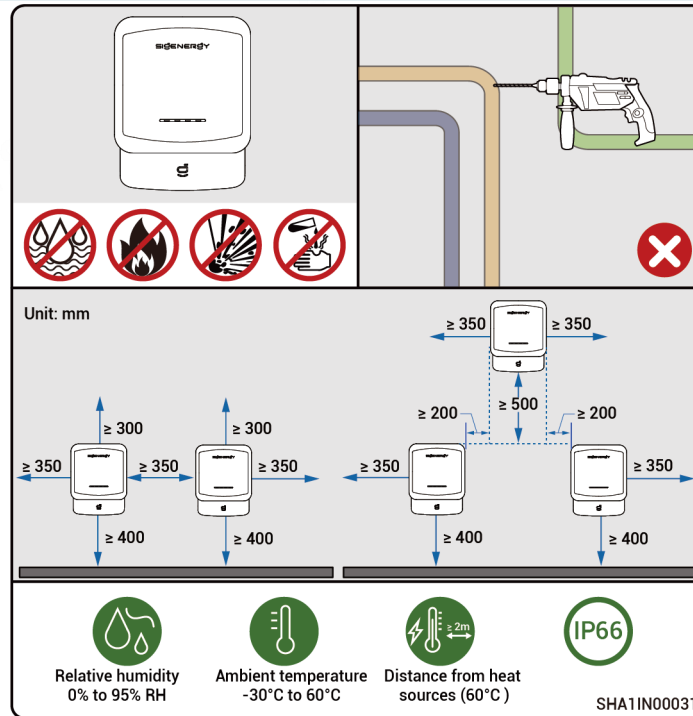

4 Installation

1 Please check the corresponding operation diagram according to the received mounting parts.

Appearance 1: Wall scenes, such as solid bricks and concrete

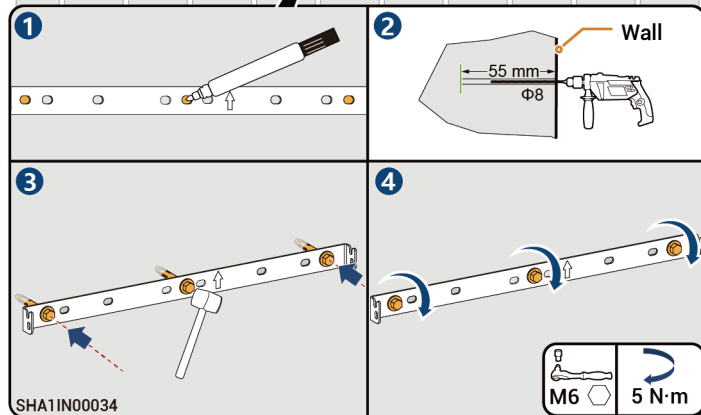
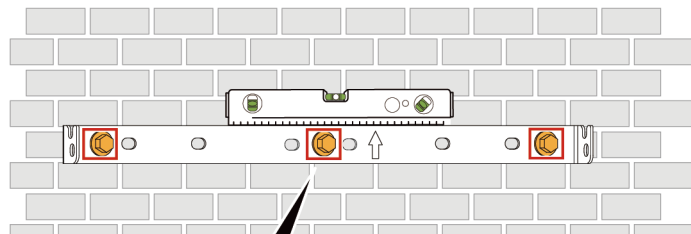
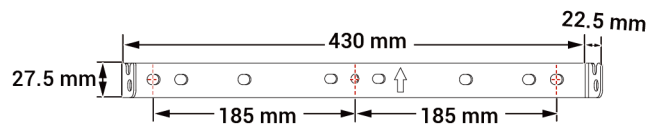

Appearance 2: Wall scenes, such as solid bricks and concrete

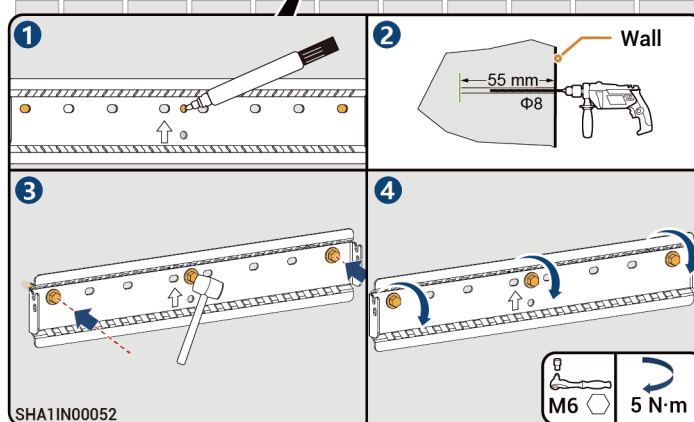
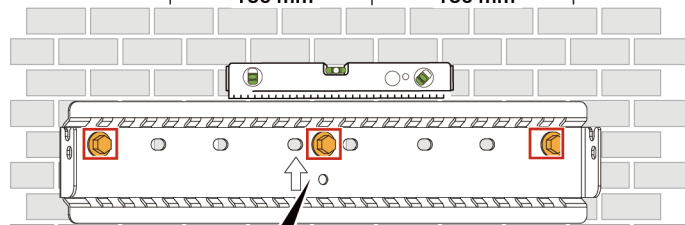
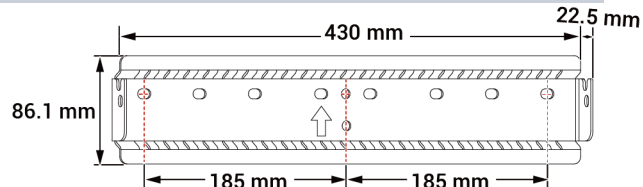

Appearance 2: Wooden wall scenes

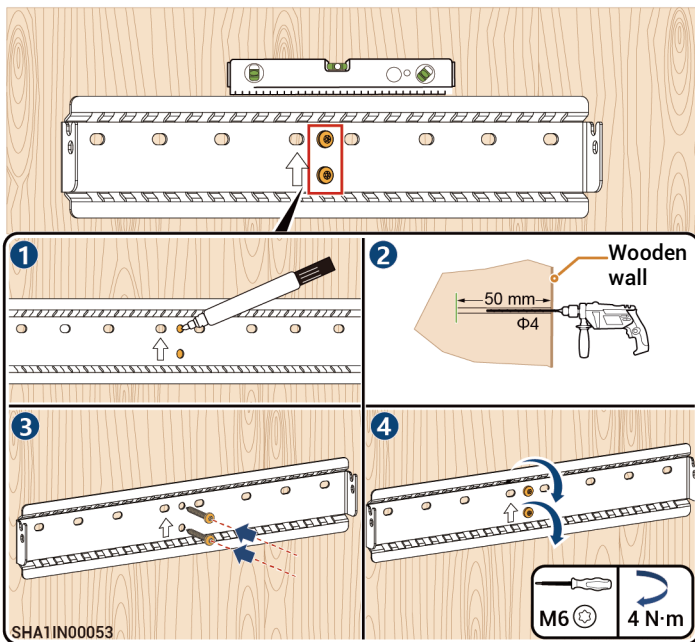
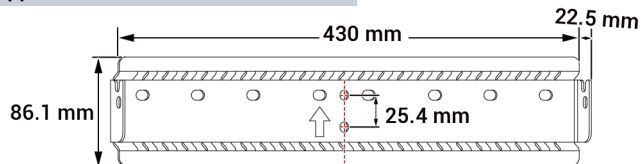

2

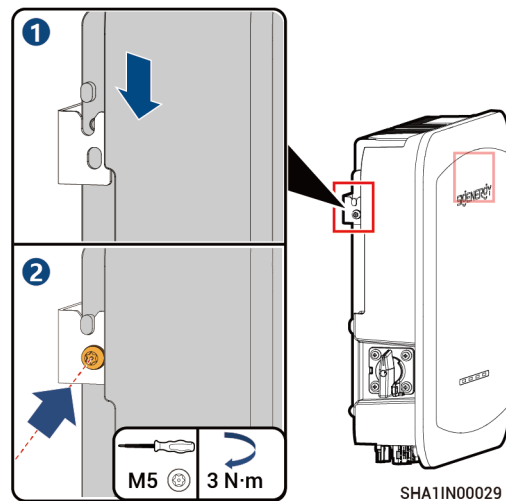

Tips

We recommend that you follow step ②, and you can drill the holes based on your actual needs.

5 Cable Connection and Part Installation

5.1 Interface Relationship

Tips

- Bind the power cable separately from the signal cable.
- Power sensors need to be purchased from our official channel.
- For the appearance and specific wiring of the power sensor, refer to the user manual shipped with the box.

! Danger
Before wiring, please make sure the inverter and the connected equipment are uncharged.

All optical networking

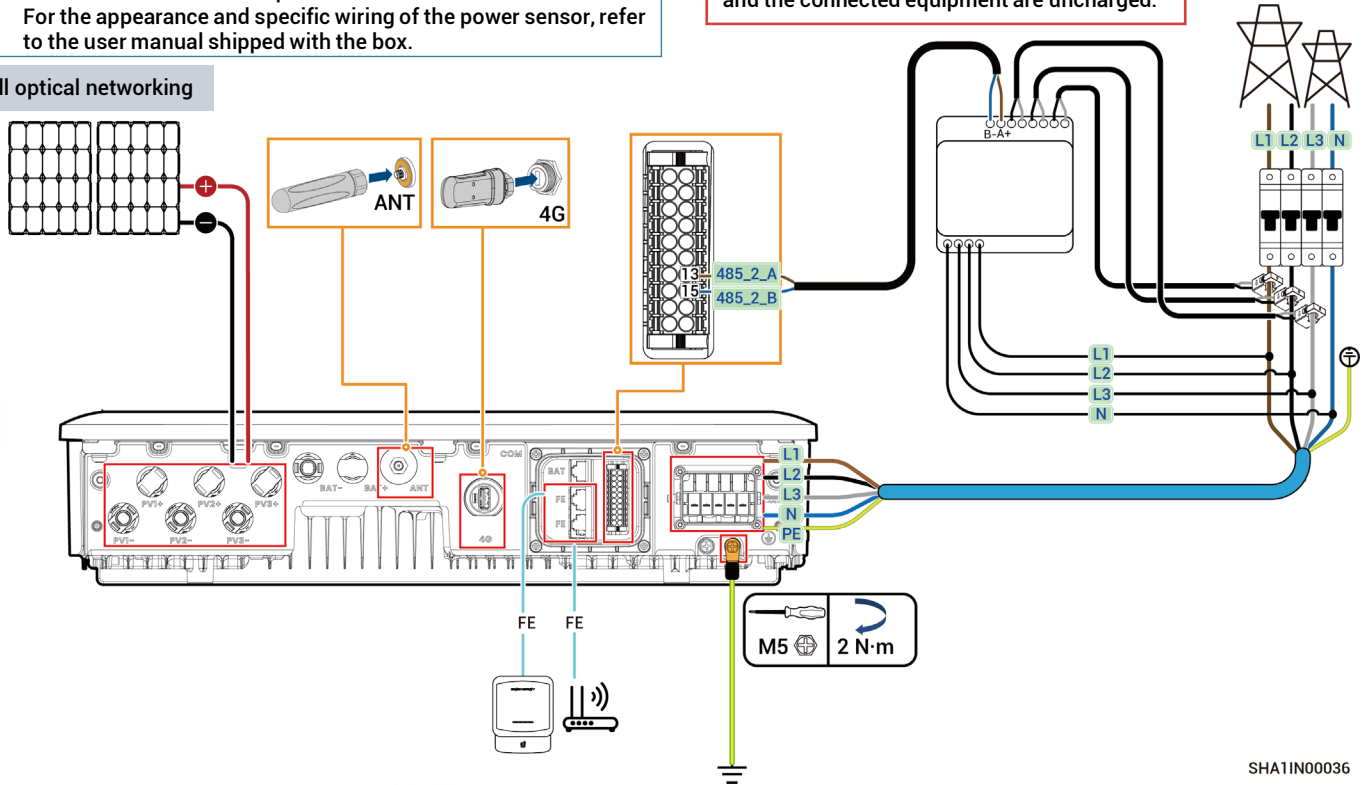

PV storage and charging system wiring

Tips

- Power sensors need to be purchased from our official channel.
- For the appearance and specific wiring of the power sensor, refer to the user manual shipped with the box.
- For specific operations interfacing with SigenStor BC, please refer to the Installation Guide for the corresponding model.

Danger

Before wiring, please make sure the inverter and the connected equipment are uncharged.

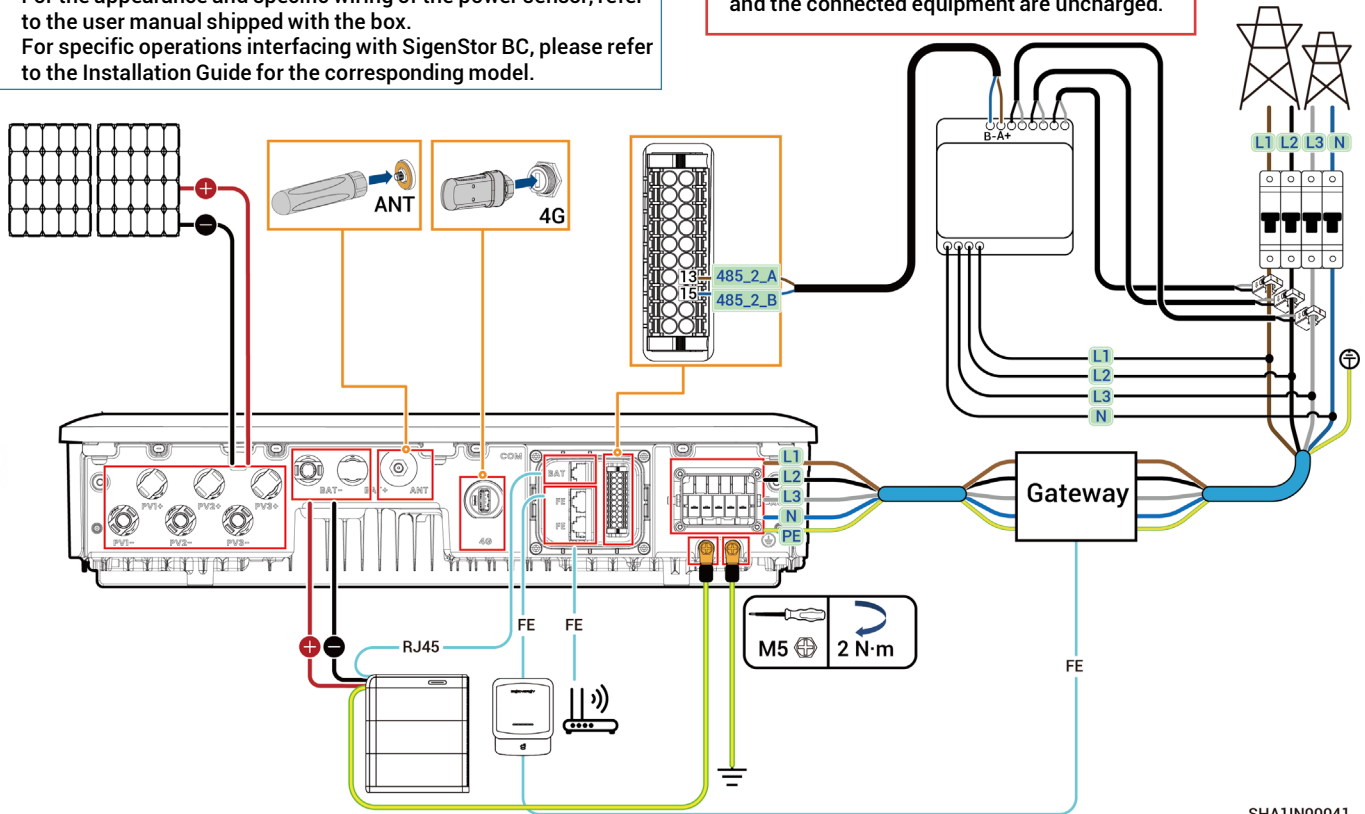

5.2 Description of COM Port

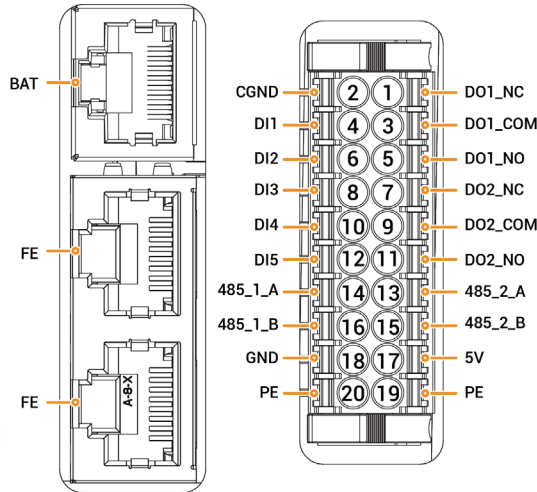

STA1IN00005

Description	COM		Signen Sensor TP-DH (SDM630MO DBUS V2)	Signen Sensor TP-CT120-DH (SDM630 MCT 40mA/120A)	Signen Sensor TP-CT300-DH (SDM630MCT 40mA/300A)	Signen Sensor TP-CT600-DH (SDM630MCT V2/600A)
	Interface	Definitions				
Connect to SignenStor BC of our company.	BAT	Battery pack communication port	-	-	-	-
Two Ethernet ports, of which one can be connected to the router, and the other can be connected to other devices (e.g., inverter, Gateway, etc.)	FE	High-speed Ethernet port	-	-	-	-
(Reserved) For power scheduling, such as DRM and ripple control.	DI1	DI1 input signal 1	-	-	-	-
	DI2	DI2 input signal 2	-	-	-	-
	DI3	DI3 input signal 3	-	-	-	-
	DI4	DI4 input signal 4	-	-	-	-
	DI5	DI5 input signal 5	-	-	-	-
	CGND	Signal GND	-	-	-	-
RS485-1, custom RS485 port.	485_1_A	RS485 signal 1_A+	-	-	-	-
	485_1_B	RS485 signal 1_B-	-	-	-	-
	PE	PE signal-shield ground	-	-	-	-
RS485-2, connected to the COM port of the grid-connected power sensor.	485_2_A	RS485 signal 2_A+	A+	14	14	14
	485_2_B	RS485 signal 2_B-	B-	13	13	13
	PE	PE signal-shield ground	-	-	-	-
(Reserved) DO1, connecting to a third-party smart power equipment, such as switch controller and heat pump.	DO1_NC	Dry contact 1 - normally closed	-	-	-	-
	DO1_COM	Dry contact 1 - common point	-	-	-	-
	DO1_NO	Dry contact 1 - normally open	-	-	-	-
(Reserved) DO2, connecting to a third-party smart power equipment, such as switch controller and heat pump.	DO2_NC	Dry contact 2 - normally closed	-	-	-	-
	DO2_COM	Dry contact 2 - common point	-	-	-	-
	DO2_NO	Dry contact 2 - normally open	-	-	-	-
(Reserved) 5V power supply, used for supplying power to the SUB 1G communication module.	5 V	5V power supply	-	-	-	-
	GND	5V power supply GND	-	-	-	-

5.3 Ground Cable

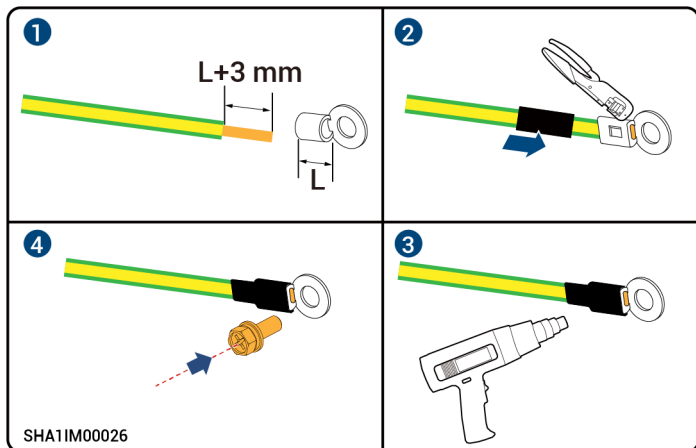

5.4 AC Cable

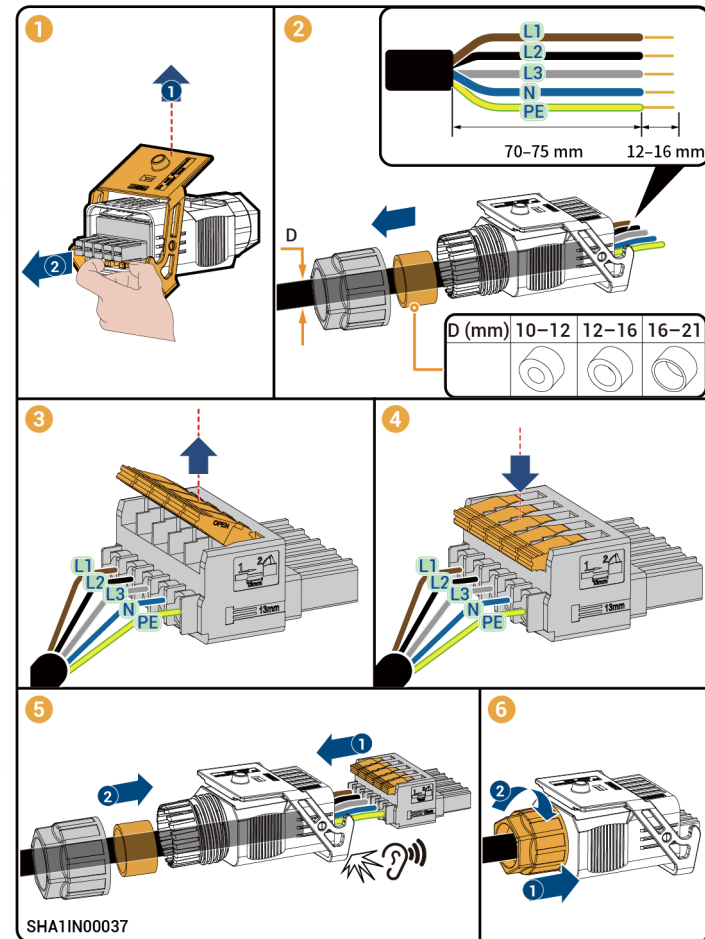

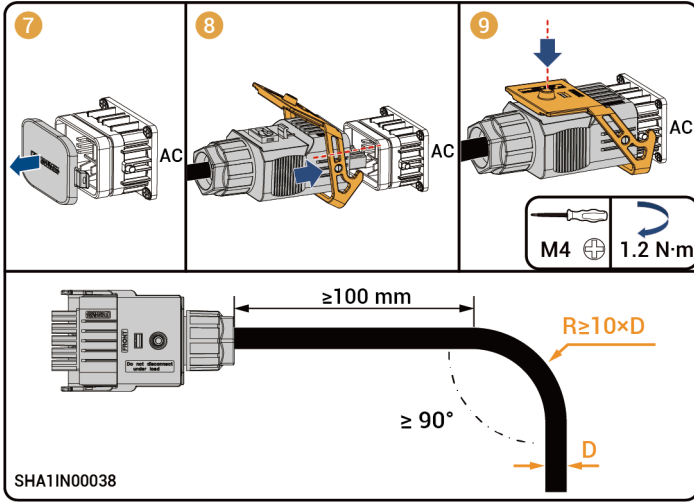

5.5 Signal Cable

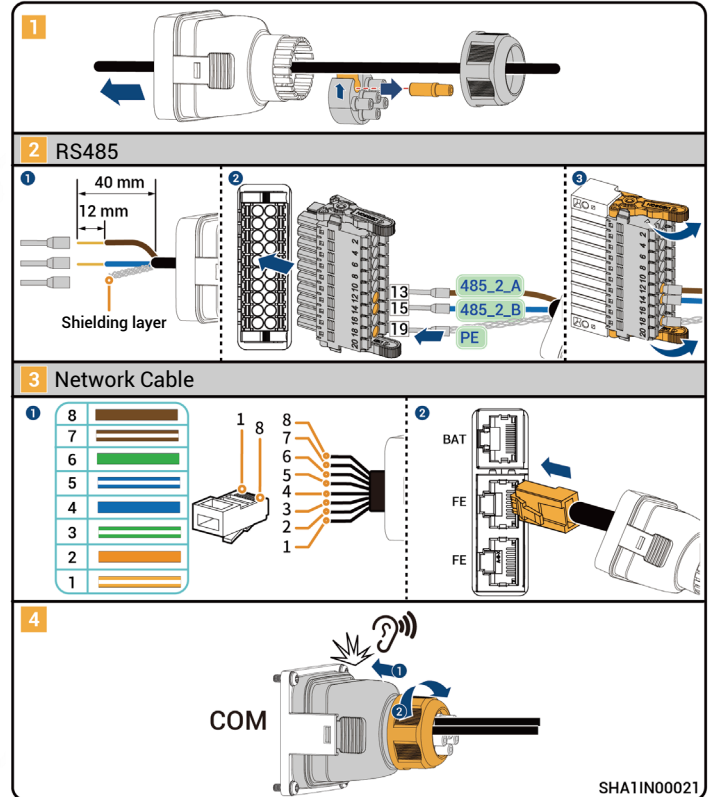

5.6 DC Input Line

Tips

- Please make sure that the circuit breaker on the PV side is electrically neutral before connection.
- The DC line is connected from the photovoltaic string to the inverter.

1 Positive metal terminal

8 to 10 mm

Negative metal terminal

2 H4TC0003

3 Positive connector

Negative connector

4

SSA1IN00024

Power range	Configuration of PV string
3.0 to 8.0 kW	Connect 2 ways of strings (PV1+/PV2+/PV1-/PV2-)
10.0 to 12.0 kW	Connect 3 ways of strings (PV1+/PV2+/PV1-/PV2-/PV3+/PV3-) PV2 and PV3 share one MPPT. The model and quantity of the connected PV string need to be the same.

5

6

PV+

PV-

7

PV+

PV-

Caution

If the voltage is negative, it represents a polarity error, please correct it in time.

SHA1IN00023

5.7 (Optional) Replacement of SIM Card of Sigen CommMod

Tips

- If the Sigen CommMod you buy does not come with an SIM card or free 4G traffic runs out, you can follow this step to replace an SIM card.
- Please replace the SIM card in the Sigen CommMod with a SIM card from the country or region where the device is located. Recommended data plan: $\geq 50 \text{ MB/month} \times N$. (Wherein, N is the number of inverter unit)
- If you only hear one "click" sound when assembling Sigen CommMod in the step ③, the other side shall be properly assembled.

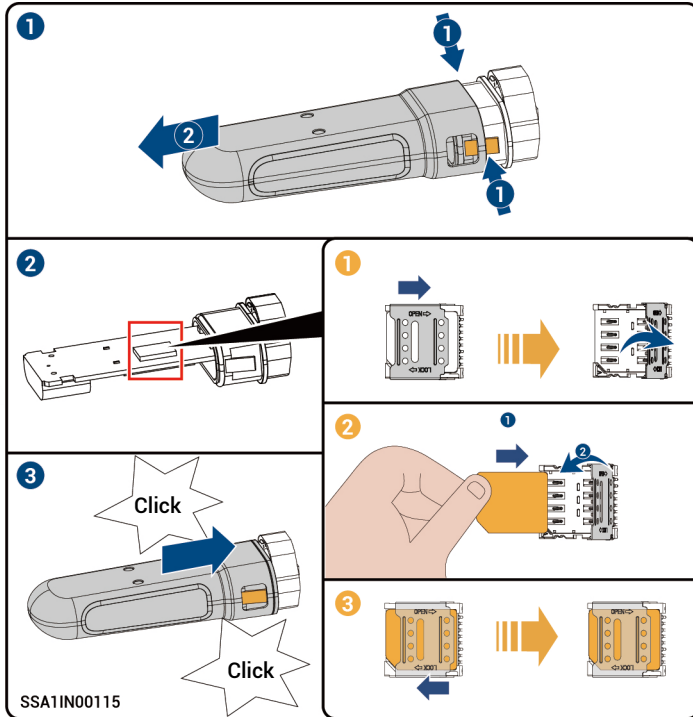

5.8 Installation of Sigen CommMod

Tips

When using 4G communication, Sigen CommMod shall be installed.

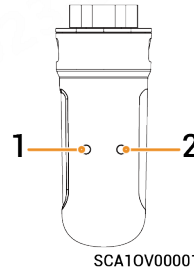

No.	Indicator	Description
1	Power light	-
2	Network status light	<ul style="list-style-type: none"> • Slow flashing (200ms on/1800ms off): Connecting to the network • Slow flashing (1800ms on/200ms off): Standby • Flashing (125ms on/125ms off): Transferring data

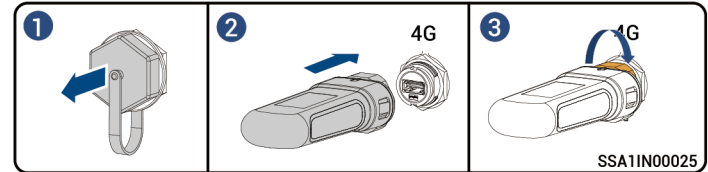

5.9 Installation of the WLAN Antenna

Tips

- When using WLAN communication, an antenna shall be installed.
- To ensure good communication, the antenna must be tightened clockwise. The antenna rod is tightened up when it cannot be easily turned counterclockwise.

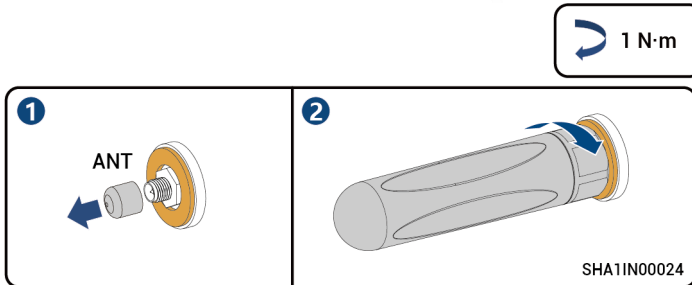

5.10 Installation of Decorative cover

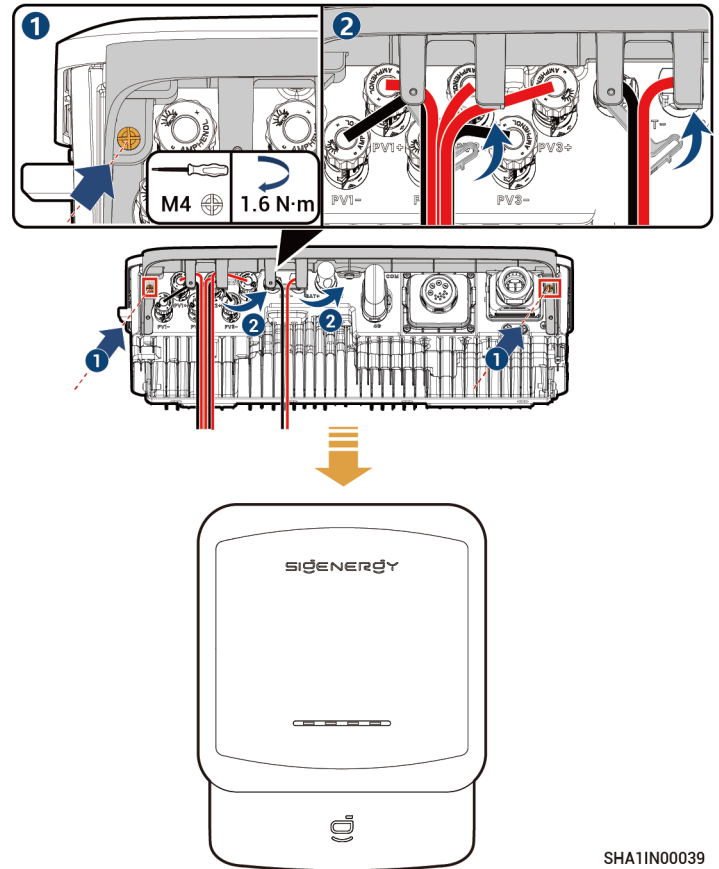

6 Inspections After Installation

No.	Check Item
1	The equipment is securely installed.
2	Ground cables, DC cables, AC cables, signal cables, etc. are installed accurately, with no omissions.
3	Lock screws or connectors are installed in place without any looseness.
4	Cutouts of cable ties are free of burr or sharp edges.
5	"DC SWICH" is in the "OFF" state.
6	Unused ports are protected with water-proof covers or plugs.
7	No construction residue inside and outside the equipment.

7 Power-on

1. Turn on the upstream AC switch.
2. Rotate the "DC SWITCH" to the "ON" position.
3. Observe the status of the indicator on the front of the inverter to understand the device status.



DC indicator













AC indicator

Signal
indicator

Energy storage
indicator

SHA10V00006

Indicator	Color	Status	Meaning
	White	Steady on	The DC side has been connected, but is not running.
	Green	Steady on	The DC side is running.
	Grey	Off	The DC side is not connected.
	Orange	Blink	The DC side fails.
	Red	Steady on	The inverter fails.
	White	Steady on	The AC side has been connected, but is not running.
	Green	Steady on	Running in an on-grid state.
	Blue	Steady on	Running in an off-grid state.
	Grey	Off	The AC side is not connected.
	Blue	Blink	Running with overload in an off-grid state.
	Orange	Blink	The AC side fails.
	Red	Steady on	The inverter fails.

Indicator	Color	Status	Meaning
		Off	The management system is not connected.
		Blink	The near-end APP has been connected.
		Steady on	The management system has been connected via FE or WLAN.
		Steady on	The management system has been connected via 4G.
		Blink	Insufficient traffic for Sigen CommMod.
		Steady on	All SigenStor BATs have been connected, but are not running.
		Blink	SigenStor BAT is being charged.
		Blink	SigenStor BAT is being discharged.
		Off	All SigenStor BATs are dormant or not connected.
		Blink	Part of SigenStor BATs fail.
		Steady on	All SigenStor BATs fail.

8 Download and Startup of mySigen App

- 1 Please visit <https://www.sigenergy.com> and go to "Partner" → "Register Now" and sign up for your account.
- 2 Download the mySigen app to initiate the creation of a new system for your equipment.

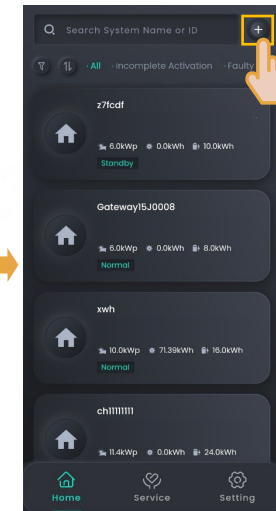
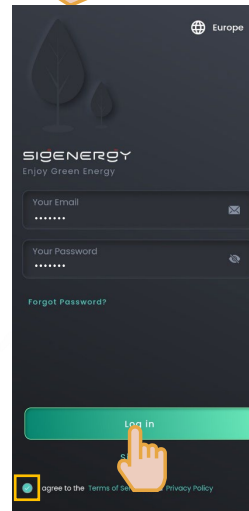
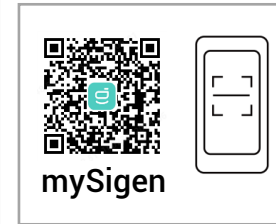

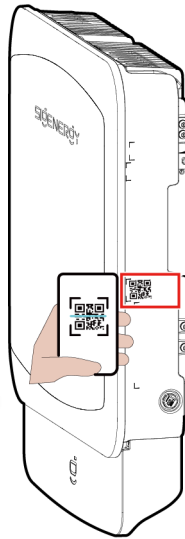
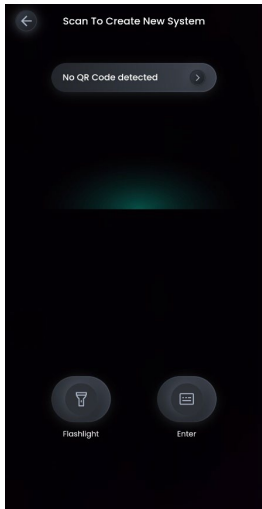

or

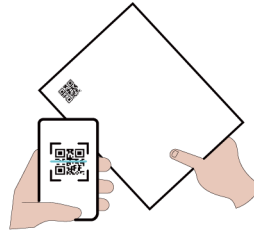

According to the interface prompts, complete the startup or refer to the "mySigen App Creating New Systems Guide" to obtain the operation method of startup.



SHA1IN00036

Scan the SN code label on the attached documents. If it is lost, scan the SN code on the side of the inverter.

3 An installer should ask the owner to check the email titled "sigencloud" to activate the account within 24 hours after creating a new system.

Sigenergy Technology Co., Ltd.



Website	LinkedIn	YouTube
---------	----------	---------

www.sigenergy.com



Copyright © Sigenergy Technology Co., Ltd. 2025. All rights reserved.

Description in this document may contain predictive statements regarding financial and operating results, product portfolio, new technology, configurations and features of product. Several factors could cause difference between actual results and those expressed or implied in the predictive statements. Therefore, description in this document is provided for reference purpose only and constitutes neither an offer nor an acceptance. Sigenergy Technology Co., Ltd. may change the information at any time without notice.